

U.S. Department of Housing and Urban Development
Office of Policy Development and Research

Published by:
ANALYTECH



Conserving Energy in Older Homes

A Do-It-Yourself Manual



Conserving Energy in Older Homes

A Do-It-Yourself Manual

Published by:



1982, 1983

Prepared Under Contract H-5229 by

Applied Management Sciences
Silver Spring, Maryland
August 1981

Jeffrey M. Seisler  Suite C-30, 915 King St., Alexandria, VA. 22314 (703)836-7962

Table of Contents

Part I: The Conservation Dilemma

Chapter	Page
1 Introduction	3
1. What Can Be Done To Conserve Energy in Older Homes?.....	3
2. Energy In Your Home: Where You Use It, How You Lose It	4
3. How To Use This Manual.....	5
2 Inspecting Your Home for Energy Conservation	7

Part II: The Conservation Solutions

Chapter	Page
3 Simple, Inexpensive Ways To Save Energy	15
1. Simple Adjustments To The House.....	15
2. Heating and Cooling Equipment	16
3. Water Heaters	17
4 Reducing Air Leaks and Heat Loss	19
1. Attics.....	19
2. Walls	22
3. Floors and Untreated Spaces	25
4. Windows	26
5. Doors	31
5 Energy Conservation Opportunities for Mechanical Equipment	35
1. Radiator Heating Systems	35
2. Gravity and Forced Air Heating Systems	38
3. Electric Resistance Heating Systems	39
4. Other Older Home Systems	40
Index	44

The Conservation Dilemma

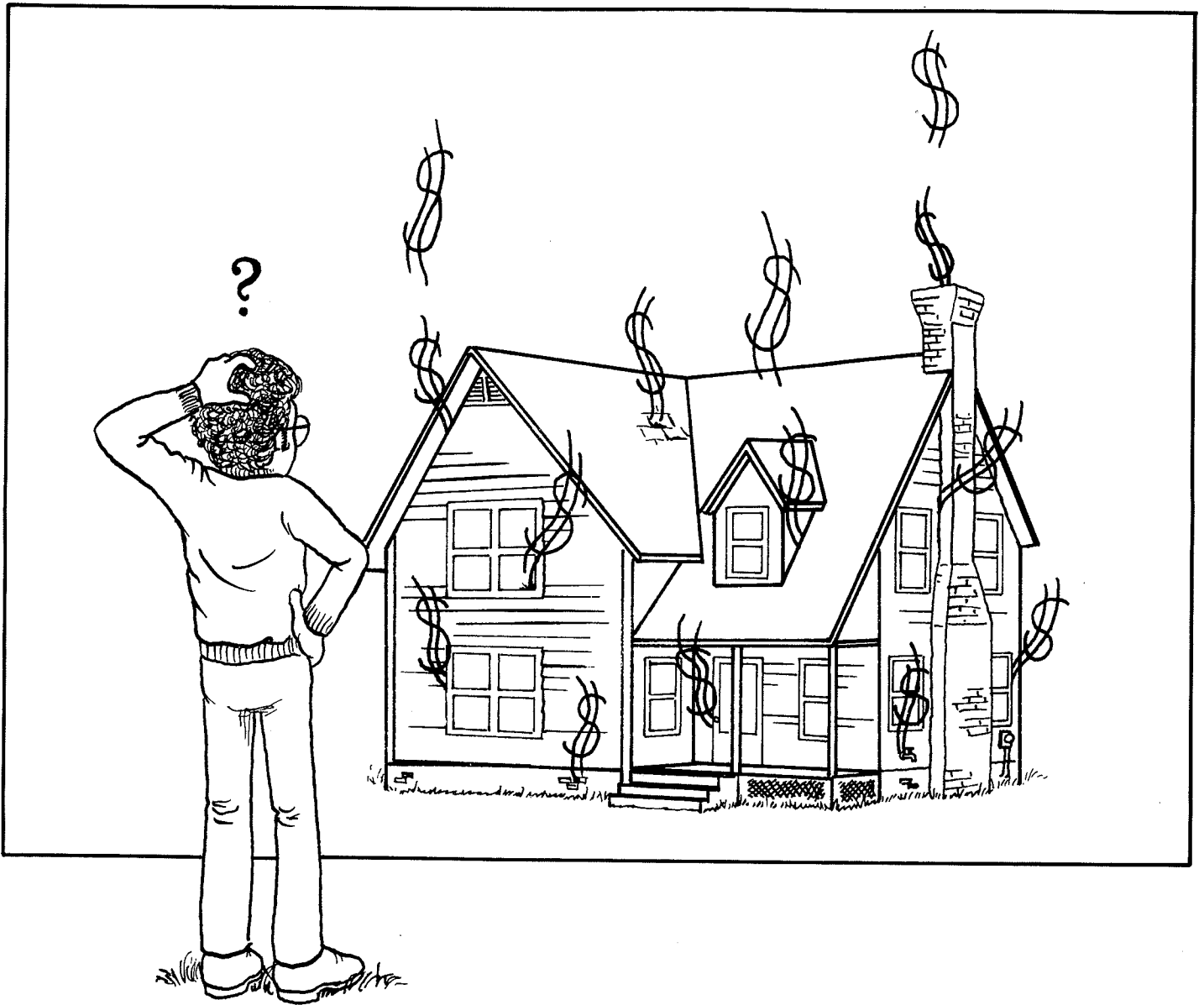



Introduction

If You Live in a One- or Two-Family Home Built Before 1940, Then This Book is For You.

This book is designed specifically for people who live in homes built before 1940. It will help you make wise decisions about saving energy and money. Using this book you will learn how to reduce energy waste in your home, which will help you offset rising energy prices. Remember, energy conservation means using energy more wisely and efficiently and does not mean that you have to sacrifice comfort to do so.

While there are similar conservation techniques for old homes as well as contemporary homes, there are many features in older homes that require special consideration. From an energy perspective, older homes are special because they were built under conditions entirely different from those existing today. This book is designed to address these unique features of older homes.

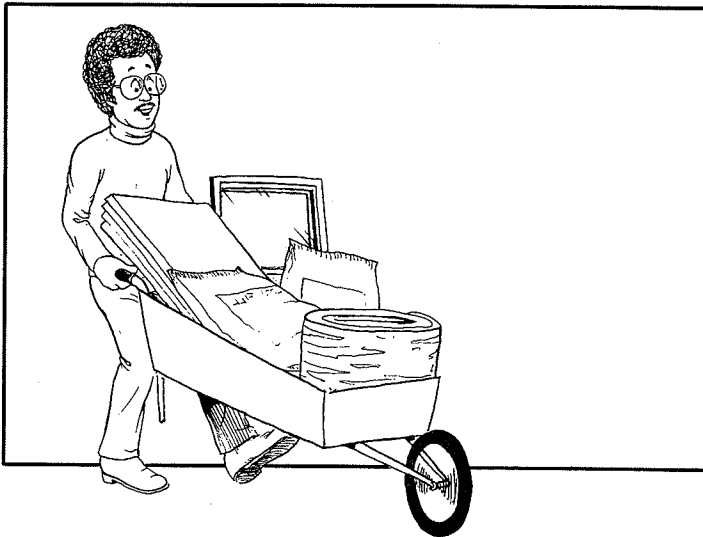

When Thinking About Energy Conservation in Older Homes, There are Many Building Features that Deserve Special Attention.

Different construction practices in older homes, and varied design features present special problems when tightening your house for improved energy use. For example:

- Brick walls without hollow airspaces cannot be insulated easily.

- Installing attic insulation sometimes is difficult due to inaccessible (or only partially accessible) attic spaces beneath slanted or odd-shaped roofs.
- Old double-hung, wood-frame windows, as well as metal casement windows, usually need major improvements to reduce drafts and air leaks.
- Unheated spaces beneath floors are not always accessible to allow installation of under-floor insulation.

Residential energy use before 1940 was considerably different than in contemporary homes. Coal and wood were the predominant heating fuels, and central heating systems were not as common as they are today. As a result, mechanical equipment for heating, hot water, and cooling may require special attention:

- Burners on old oil heaters, in many cases, are oversized and need improvement.
- Water heating for radiators as well as domestic purposes (washing, cleaning) often is done in one large central boiler, meaning that energy is wasted during summer months when hot water for heating is not needed.

In addition to these typical differences between older and newer homes, age also plays an important part in the thermal condition of old homes. For example:

- Constant exposure to weather has led to deterioration of many older homes' exterior finishes and wood components such as window and door frames, reducing their ability to function as efficiently as newer homes.
- Sagging floors and settling of the foundations of older homes can cause radiators to shift, which can result in the less efficient operation of steam or hot water heating systems.

What Can be Done to Conserve Energy in Older Homes?

Many of the typical conservation techniques apply to old homes as well as contemporary homes. This manual discusses many of the standard conservation measures but specifically focuses on those features of older homes that require special attention. For example, the manual describes the best use of entrance vestibules and transoms (windows over doors) to help



Introduction

save energy. Interior and exterior caulking are discussed, as is the proper use of vapor barriers when insulating attics, walls, and floors. Mechanical systems in older homes are addressed, so that the efficiency of radiator systems (water or steam) as well as forced air and gravity air systems can be improved.

The movement of heat within and around your house also must be considered when inspecting your home for its energy conservation potential (see Chapter 2) and when considering which conservation measures to install. The pictures that follow will help you understand some of the basic characteristics of heat movement, and will help you identify energy use and energy waste in your older home. By applying the knowledge you will gain from reading this manual, you will learn how to improve the condition of your home and reduce its energy use.



ENERGY: WHERE YOU USE IT

As you read this manual, you will discover more about the operation and construction of your older home so that you will be better equipped to make energy-saving improvements. Keep in mind, however, that energy conservation is not a single-item, single-time action. The initial expense of some conservation materials, and the installation time required, means that the process for making your home more energy efficient may have to be taken one-step-at-a-time over a number of heating and cooling seasons.

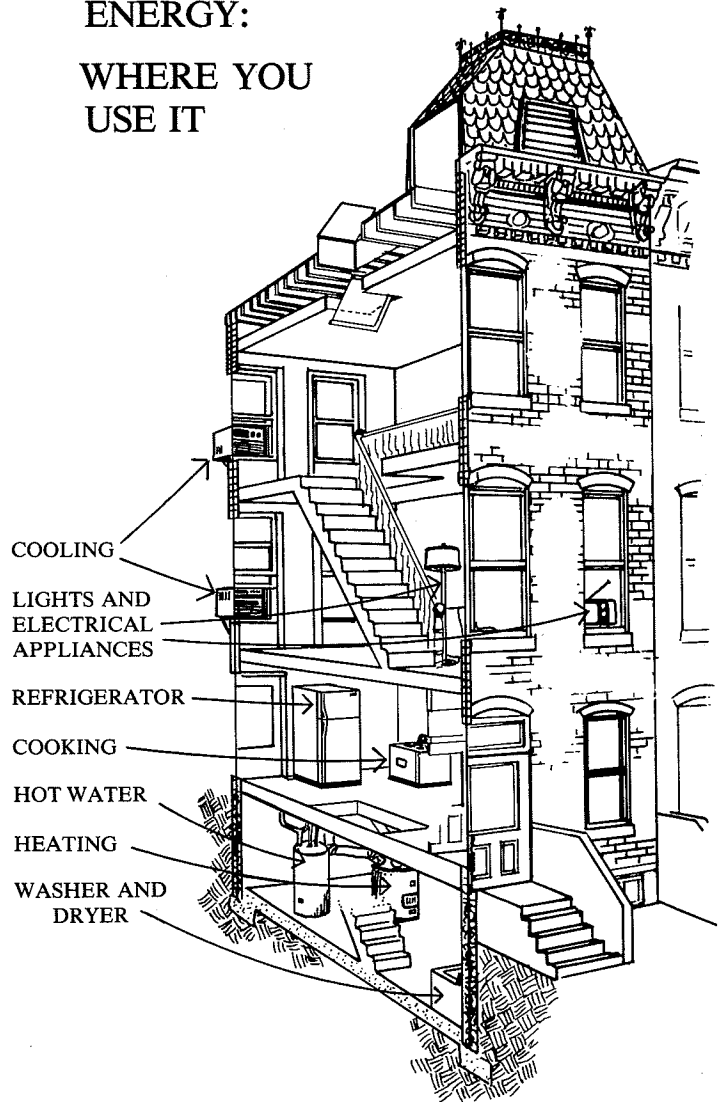

Energy in Your Home: Where You Use It, How You Lose It.

The way to conserve energy yet remain comfortable in your home is to maintain a sensible balance in summer and winter between the energy used inside your home and the outside weather conditions that will affect your comfort. To achieve and maintain this balance, you have to understand some of the very basic ways in which energy use and energy waste occur in a house.



HOW YOU LOSE IT!

Every leak in your home, no matter how small, allows valuable energy to escape. Remember, hot air tends to rise, while cool air tends to sink.

Most building materials are good conductors of heat. Insulating materials are used to reduce heat loss. Insulating materials are needed in those parts of your home that are prone to heat loss, such as in attics, floors over unheated spaces, and walls.

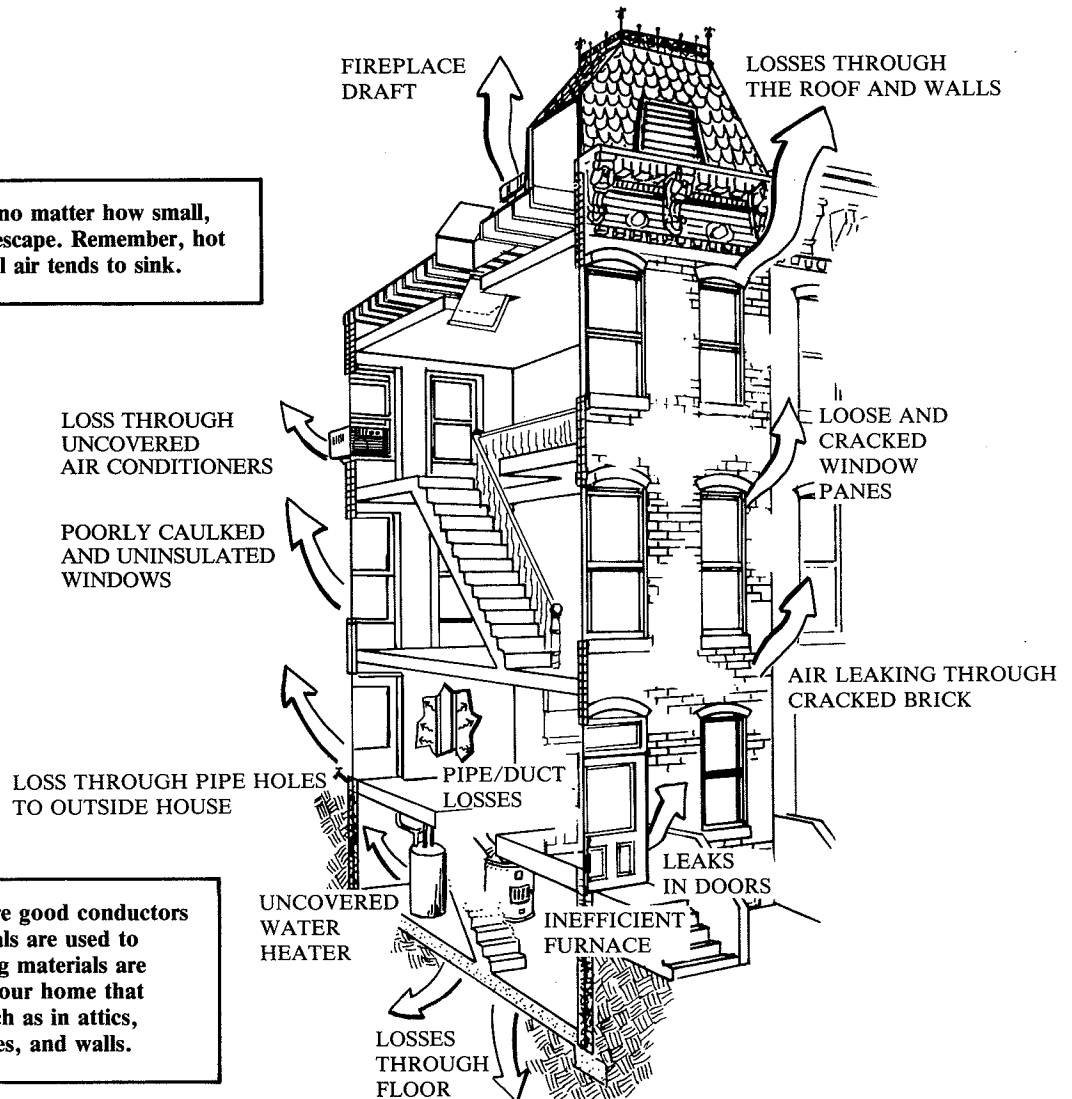

How to Use This Manual

This manual consists of two parts. Part 1, The Conservation Dilemma, will help you identify energy loss and energy saving potential in your home. Part 1 consists of two chapters: Chapter 1, the Introduction, and Chapter 2, Inspecting Your Home for Energy Conservation. Chapter 2 highlights the types of energy-related problems common to most older homes.

Part II, The Conservation Solutions, which includes Chapters 3, 4, and 5, provides a more in-depth look at energy

conservation ideas for older homes. Chapter 3, Simple, Inexpensive Ways to Save Energy, suggests a few ways to reduce immediately your energy use. Chapter 4, Reducing Air Leaks and Heat Loss, discusses conservation solutions related to old home attics, walls, floors, windows, and doors. Chapter 5, Conservation Opportunities for Mechanical Equipment, examines ways typical pre-1940 heating and cooling equipment can be operated most efficiently. An index is included at the back of the book to help guide readers to specific information contained within this manual.



Inspecting Your Home for Energy Conservation

This inspection is designed to help you identify energy conservation opportunities in your home. The inspection should take less than an hour to complete and will help you examine both the structural and mechanical systems of your home.

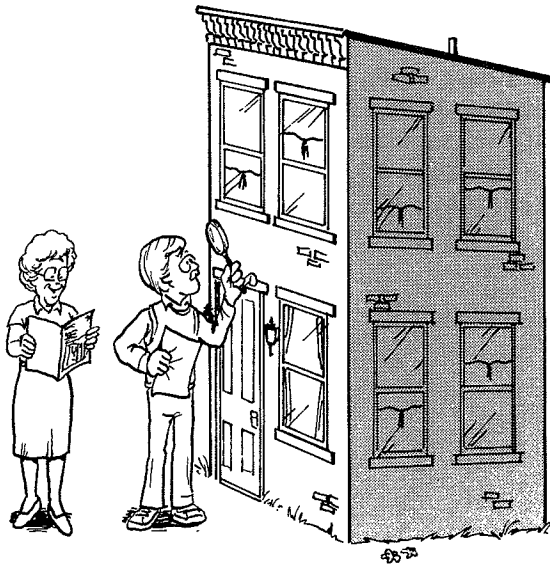

Answer each question after you have examined the appropriate part of the house. If the answer you checked has an arrow next to it, it means that more should be done to improve the energy efficiency of your home. Each of the arrows points to one or more symbols and appropriate page numbers in the manual that will provide you with information on the corrective action that is needed. If you checked the box with no arrow next to it, no action should be required and proceed to the next question.

How Much Will It Cost?

\$ = \$ 0 - 100
 \$\$ = \$101 - 300
 \$\$\$ = \$301 - and up



One, two, or three dollar signs appear above each of the conservation symbols. These will tell you the approximate cost of the recommended conservation action. These cost estimates are based on information collected in 1981 and should be used for general reference only.

Begin the Inspection Here

Note: For some simple, low cost ways to save energy, be sure to read thoroughly Chapter 3 of this manual.

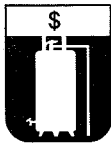

Domestic Water Heating

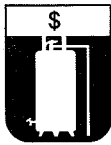
1. If you have a separate water heater (one that is not part of your heating system boiler), is it insulated?

YES 
 NO  
 p. 17

Water heater insulation will reduce heat loss through the body of the water heater. This saves energy and helps to maintain the water temperature.

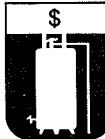
2. Are the pipes of your water heating system insulated?

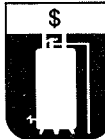
YES 
 NO  
 p. 17

Uninsulated pipes will waste heat as the hot water is distributed throughout the house. Thus, more energy will be needed to maintain an adequate supply of hot water.

HEAT LOSSES IN THE WATER HEATING SYSTEM

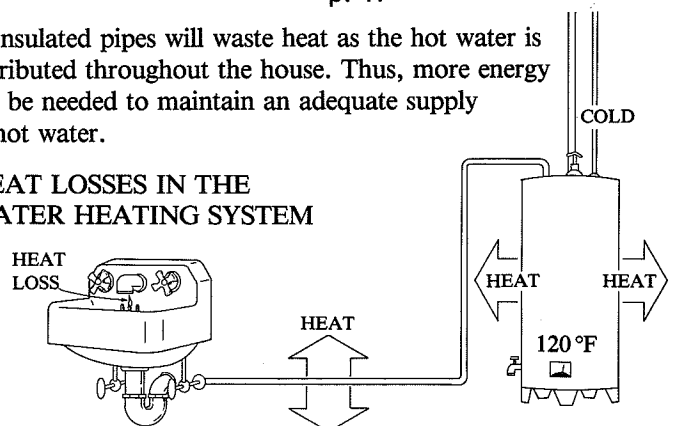



Identifying Air Leaks and Heat Loss

3. Do you have enough attic insulation?

YES

NO



p. 19

Using a ruler, measure the depth of any insulation in the attic. Insulation is measured in "R-value," which is a measure of its resistance to heat flow. The higher the R-value, the less heat will be lost through the ceiling. Multiply the depth of the existing insulation by three to gauge the approximate R-value. Check this against the table on page 20 of the manual to see if more insulation is needed.

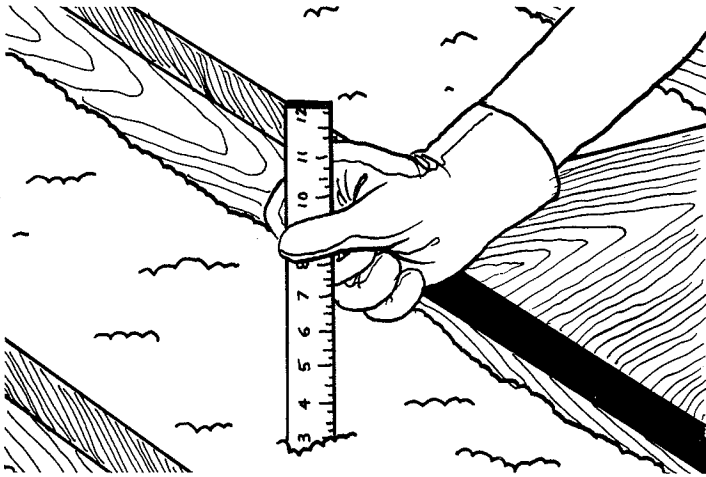

If your attic is not accessible by an attic entryway, you may need to get professional assistance to determine easiest access and if insulation is needed.

4. Are the walls of your house insulated?

YES

NO



p. 22

Do not be overly concerned about insulating masonry walls unless you are undertaking a major renovation job. You should check on the exterior walls, however, for cracks and loose mortar.

Frame walls should be checked for insulation by trying one or more of the following tests:

- **After turning off the electric power**, remove the lightswitch plate or electrical outlet plate on an outside wall. Using a flashlight, look for insulation behind or next to the outlet box. Use a pencil or other non-metallic object if you need to probe around the outlet box.

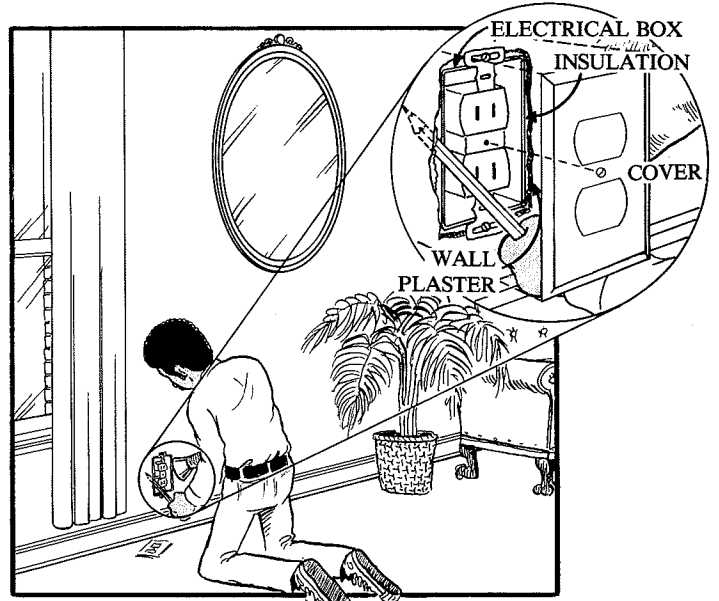

***NOTE: TURN OFF POWER TO CIRCUIT BEFORE INSPECTING ELECTRICAL BOX!**

- You can also check for insulation by poking a small hole in an outside closet wall. Using a flashlight, look into the wall cavity for insulation. To prevent drafts, be sure to reseal the opening after you have finished the test.
- If your basement is unfinished, you may be able to look up into the wall cavity along the perimeter of the basement walls or foundation. Use a flashlight to check for insulation.



5. Are all the joints on the outside of the house where different materials meet tightly sealed with caulking?

YES

NO



p. 24

ALL THESE SHOULD BE CAULKED

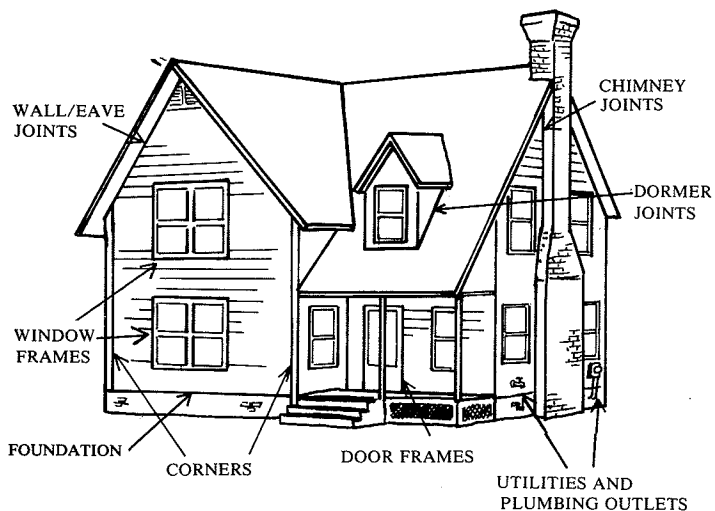

Check around window and door frames, at the joint between the foundation and walls, and at the corners to see if a tight seal exists. If there is no caulking in these areas, or if the caulking is loose or missing, answer NO to this question.

6. Are all the joints on the inside of the house tightly sealed where different building materials meet?

YES

NO

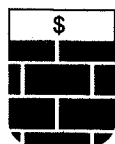

p. 24

INTERIOR CAULKING

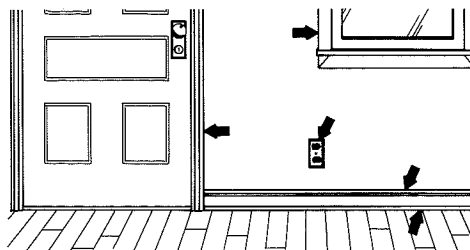

INTERIOR AREAS WHERE AIR LEAKS MAY OCCUR (AND SHOULD BE CAULKED)

Check for drafts and air leaks around window and door frames, at ceiling and floor joints, and around electrical outlets, and plumbing fixtures. Caulking on the interior of the house is important because it prevents warm air from entering the walls where condensation will form. This can decrease the effectiveness of wall insulation and cause permanent structural damage.

7. Is your unheated basement or crawl space insulated?

YES

NO



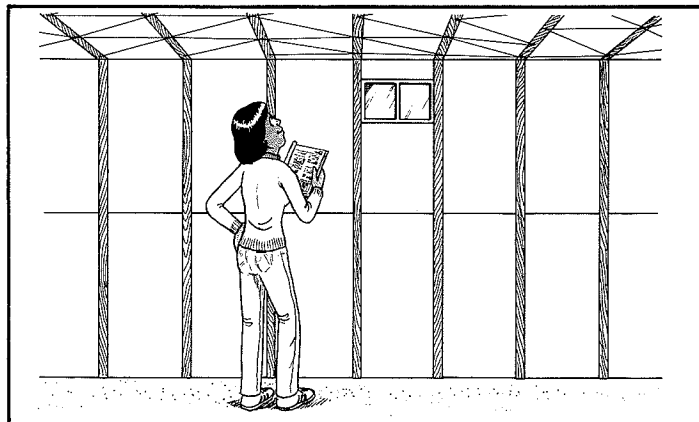

p. 25

A significant amount of heat loss occurs through the floor of the lowest heated space in the house and through the basement or crawl space. If your basement or crawl space is accessible, check for insulation between the floor joists.







8. Are the windows in your home drafty?

YES  

NO

p. 26

9. Are the doors in your home drafty?

YES  

NO

p. 31

Drafty windows can be caused by damaged window parts such as the glazing, putty, or frames. Missing or worn caulking and weatherstripping also can contribute to drafts. If you have wood-framed windows, check to see if the window sashes are tight in the frames and if the window hardware operates smoothly. Window locks should draw the two window sashes together when closed, sealing the gap between them. Locks that force the sashes apart, creating a drafty gap, should be replaced. If you have metal-framed casement windows, check the frames for rust and other obstructions (such as built-up paint) that prevent tight sealing of the window. Also check the locking hardware to make sure it tightly seals the window when closed.

Drafty doors can be caused by damaged door frames, glazing and putty, or by missing or worn weatherstripping and caulking. Drafts can occur both where the frame meets the wall and where the door meets the frame.

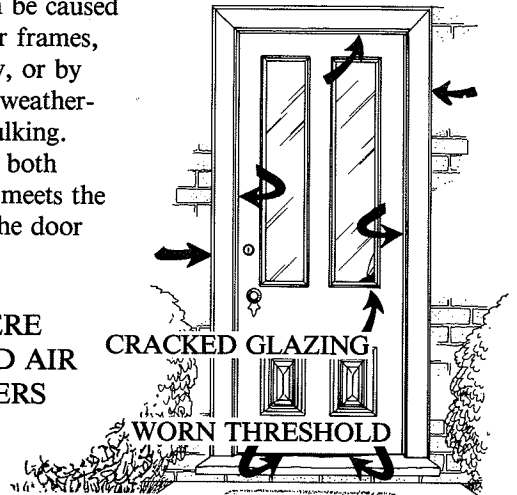

To locate the source of drafts, use a draft tester. Slowly move the tester around each window and door frame and note any movement of the plastic or paper.

WHERE
COLD AIR
ENTERS

If you have French- or Dutch-style doors, look extra carefully at the seal where the doors meet to identify places where air can get in. Worn thresholds also can contribute to drafts through doors. Check the door frame carefully for signs of air leaks.

Mechanical Equipment

Steam and Hot Water Heating Systems

Before proceeding to the next question, check your radiators to see if you have a steam or hot water heating system.

- Steam radiators have vent valves, which are designed to allow excess air to escape when the steam pressure builds up.

**STEAM
RADIATOR**

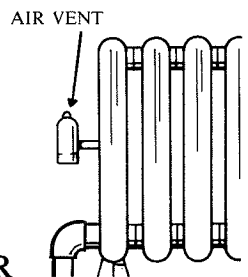



- Hot water radiators have bleeder valves, which are used to manually release excess air in the system. Water system radiators can be cast iron or convector (fin and tube) radiators.

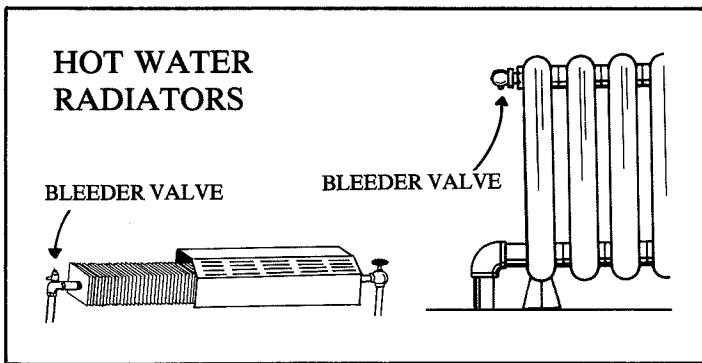

10. Do all the radiators in your home get warm when the system is on?

YES

NO → 

p. 35

Uneven heating of radiators may be due to malfunctioning or improperly adjusted valves, or to improper tilting of the radiators or radiator pipes, which prevent the efficient flow of hot water.

11. Are the heating system pipes in unheated parts of the house insulated?

YES

NO → 

p. 37

Pipe insulation can significantly reduce the amount of heat that is lost in unheated parts of the house, such as in basements or crawl spaces. Thus more of the heat produced by the boiler reaches the living space where it is needed.

Forced Air Heating Systems

12. Are the ducts in unconditioned (heated or cooled) parts of the house insulated?

YES

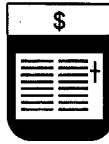
NO → 

p. 38

Duct insulation can significantly reduce the amount of heat lost in unheated parts of the house, ensuring that more of the heat produced by the furnace reaches the living areas where it is needed. For centrally air-conditioned homes, duct insulation will save energy in summer also by reducing the amount of heat from the attic, basement, or crawl space that would otherwise warm the cold air coming from the air-conditioning unit.

13. Are your heating system grilles and registers clean and unobstructed?

YES

NO → 

p. 38



Any interference with the air flow from registers and grilles will reduce the effectiveness of the system (both in winter and summer). Simple cleaning and adjustments improve the flow to rooms and thus save energy.



14. Is your furnace filter clean?

YES

NO



p. 39

A dirty furnace filter inhibits air flow and will make the furnace work harder to deliver warm air to the house in winter and, cool air in the case of central air-conditioning, in summer. Routine cleaning of permanent air filters or replacement of disposable air filters will ensure more efficient operation of the system and save energy.

Electric Heating Systems

15. Are the radiators clean and dirt free?

YES

NO

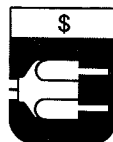

p. 39

Check to make sure the heating units are clean and free of dust. Dirt and dust act as insulators that prevent optimal heat flow.

Fireplaces

16. Does your fireplace have an operable damper that can be closed when the fireplace is not in use?

YES

NO



p. 40

An open fireplace flue generates a natural upward draft that can draw large quantities of heated air from the house. This makes the heating system work harder to maintain the desired temperature and ultimately results in energy waste.

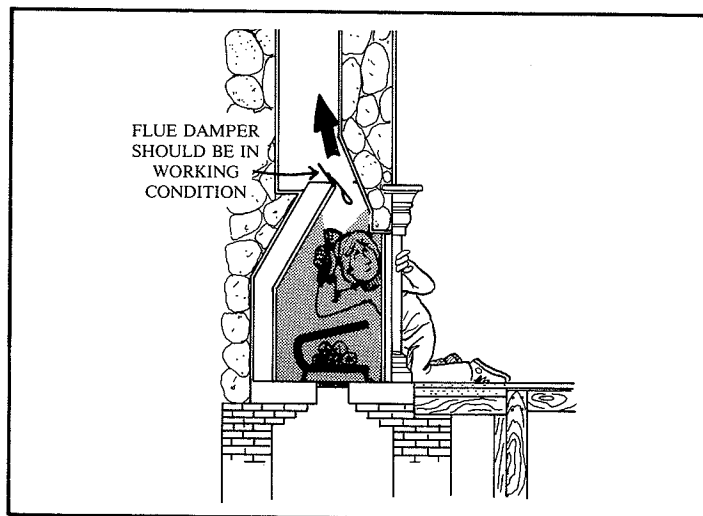

The Conservation Solutions

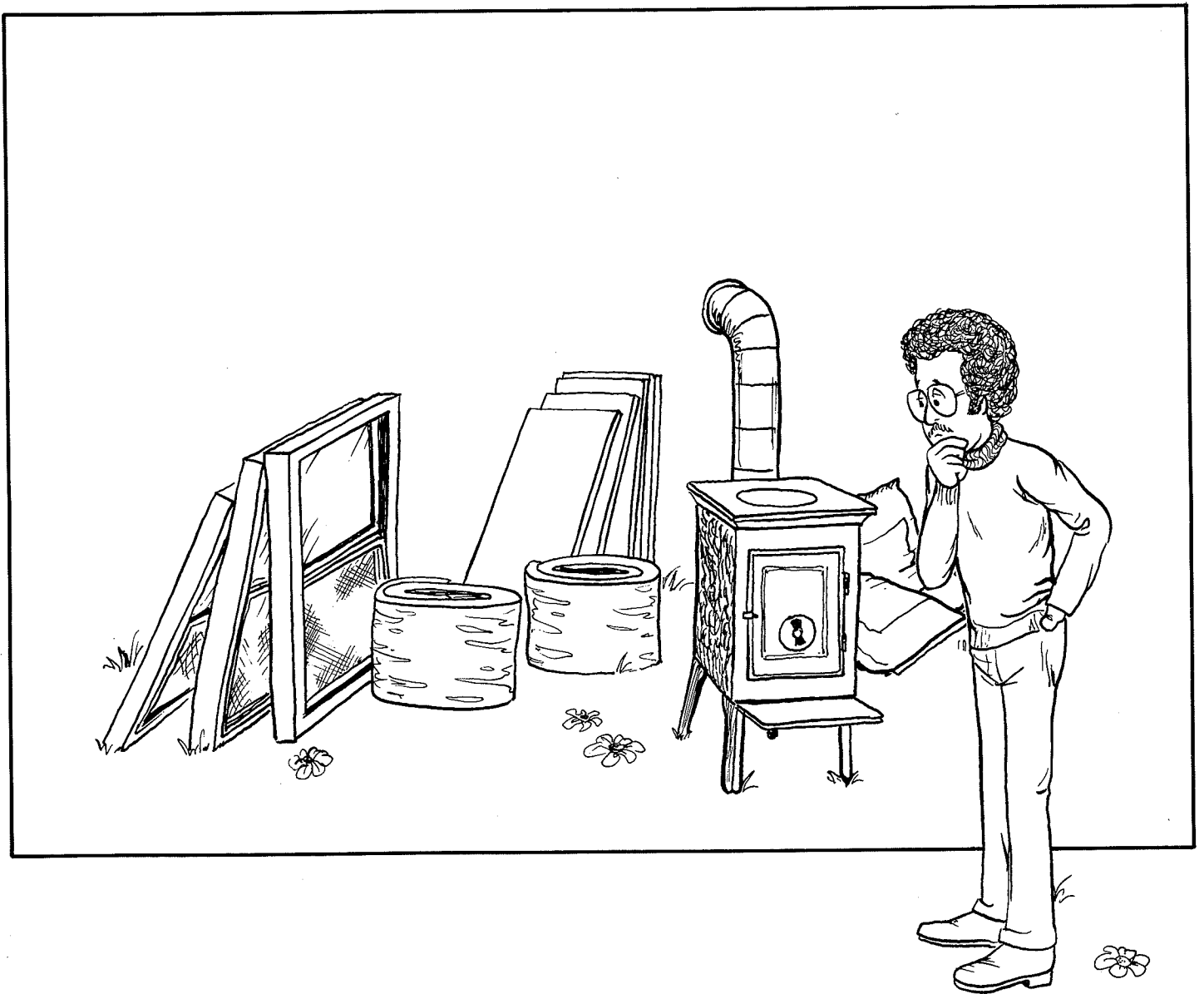



Simple, Inexpensive Ways to Save Energy

This chapter describes some simple, inexpensive, and practical energy-saving ideas that can reduce your energy expenses, regardless of the age of your home. Before you invest in other more expensive conservation measures, try some of these.

1. Simple Adjustments to the House



Many older homes are designed with useful energy saving features that increase the comfort of your home. Sometimes common sense may be your best guide for reducing energy use.

A. Use Transoms for Ventilation

Many older homes have transoms above doors, designed to increase ventilation between rooms. Open transoms can significantly improve ventilation in your home, providing greater comfort without having to rely on expensive air conditioning.

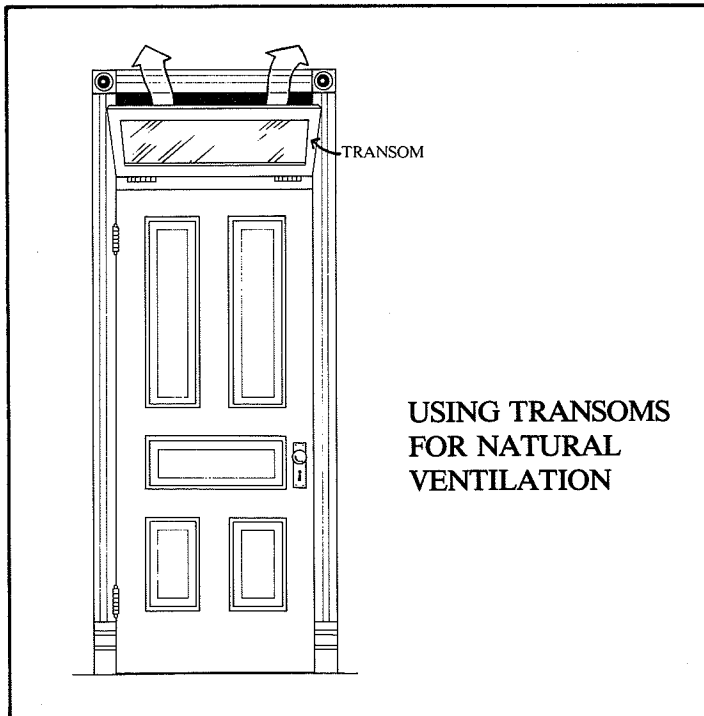

B. Use Vestibules to Their Best Advantage

Vestibules were designed and constructed in many older homes to reduce drafts and heat loss when entering or leaving the house. Open only one door at a time so that an energy-robbing draft is not created. This practical use of vestibules will save energy both in winter and summer.

THE RULE OF THE VESTIBULE:

DON'T OPEN BOTH DOORS AT THE SAME TIME!

(RULE APPLIES TO COOLING AS WELL AS HEATING)

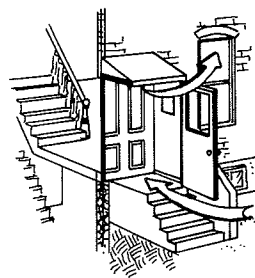

RIGHT!

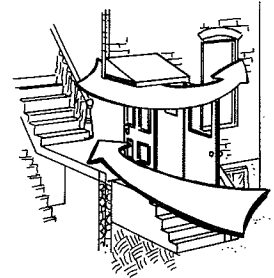

WRONG!

If the house does not have a vestibule, consider adding one to the most heavily used door as an additional "buffer zone" between the living space and the outside. This is not a simple, inexpensive conservation measure, so your decision to construct a vestibule should be made after consulting qualified contractors.

ADDING A VESTIBULE ONTO AN EXISTING PORCH

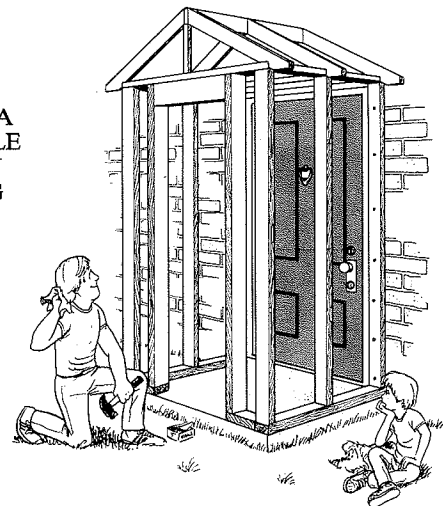



Simple, Inexpensive Ways to Save Energy

C. Close Off Unused Rooms

In today's energy conscious times, it makes little sense to heat or cool rooms that are seldom used. To save energy and money, turn off the radiator or close the heating vents in these rooms and shut the door on your way out. Occasionally, check the temperature of these rooms to make sure it doesn't get so cold that pipes in the walls will freeze.

NOTE: If your home is heated by a modern heat pump, closing vents may cause the system to operate less efficiently. Any questions regarding heat pump operation and vent closures should be referred to the manufacturer.

If your house has central air conditioning, in the summer set the thermostat at 75-80 °(F) to help reduce the burden on your cooling system.

Never set the thermostat below 55 °(F) in winter because water pipes may freeze during very cold weather.

A thermostat located on an exterior wall, or on a wall backed by an unheated space, may not reflect actual room temperature. A significant inaccuracy could cause energy waste. Using any standard indoor thermometer, measure the room temperature from a central location and compare it to the thermostat reading. If there is a variation of more than 3 or 4 degrees, you should consider having your thermostat relocated on an interior wall.

2. Heating and Cooling Equipment



Two key conservation procedures for efficient use of heating and cooling equipment are discussed below. Other simple and basic maintenance procedures for this equipment are described in Chapter 5.

A. Adjust Thermostat Settings

Adjusting thermostats is one of the simplest things you can do to save energy, both in summer and winter. In the winter set the thermostat at 65 °(F) or lower. At night, turn the thermostat down to 60 °(F). You can save up to three percent of your heating bill for every degree that you lower the thermostat over an eight-hour period.

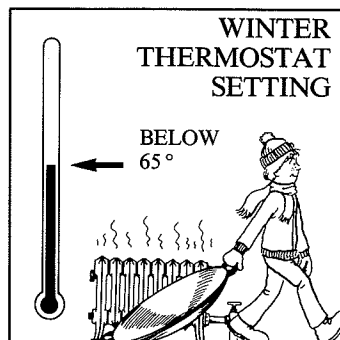
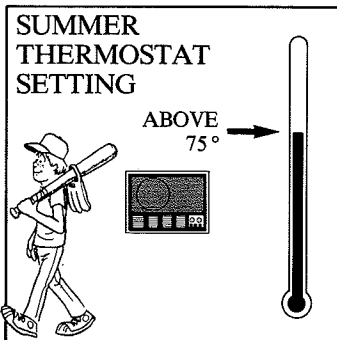

B. Turn Off Pilot Lights

If you have a gas furnace or boiler that is separate from your domestic water heater, you can save energy during summer months by turning off the pilot light. This is an easy procedure that involves turning off both the main gas valve to the heating unit and the valve to the pilot light. (The smaller pilot valve is usually located right next to the main valve.)

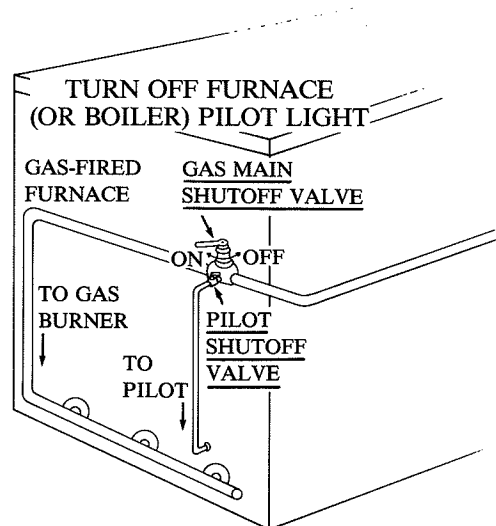



To relight the pilot light at the beginning of each heating season, follow the instructions posted on your furnace or boiler, or check with your local utility for information and assistance.

3. Water Heaters



Hot water use consumes approximately 15-25 percent of the energy used in your home. There are several good techniques for reducing the energy necessary to heat water.

A. Turn Down the Water Heater Thermostat

Water in the 120-140°F range should be adequate for all your hot water needs. If your water heater is producing water hotter than this, you may be wasting valuable energy dollars.

Turn the water heater thermostat down to the 120°F or the "low" setting, for one day. If this setting is too low for your needs, readjust the thermostat. Allow at least one day between settings for the water heater to adjust to the new setting.

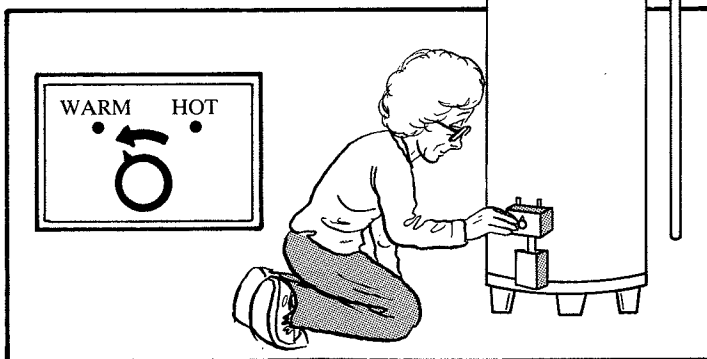

You may find that 120°F water is not hot enough to clean thoroughly the dishes in an automatic dishwasher. After reducing the water temperature, if the dishes have soap spots and are not clean, readjust the thermostat. You should not need to turn the temperature above 140°F.

B. Water Heater Insulation

Your water heater maintains a constant supply of hot water. Because heat escapes through the uninsulated water heater body, your heater uses energy even when no hot water is drawn from the tank. If your water heater is located in an unheated part of the house, escaping heat is wasted completely. Water heater insulation will reduce heat loss and make the water heater more energy efficient.

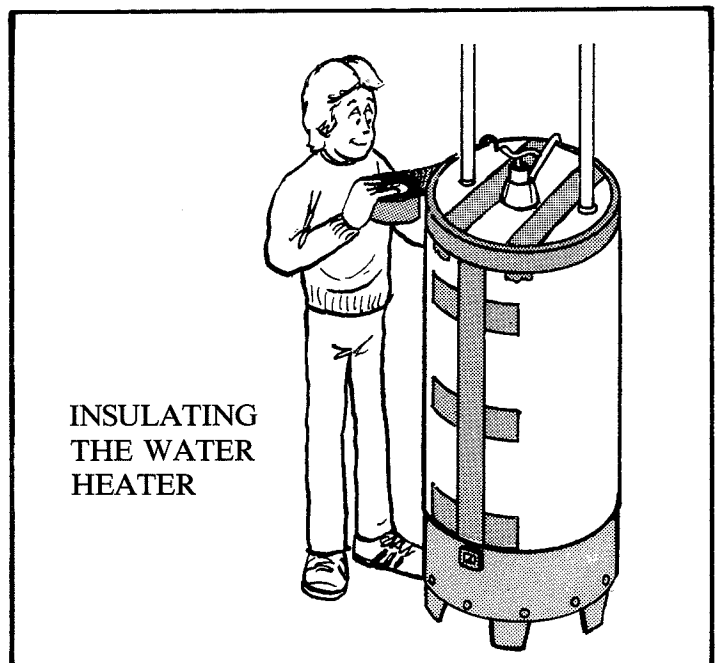

Water heater insulation kits are available at most home improvement centers and can be installed easily on most water heaters. Usually the amount of energy saved in the first year will pay for the cost of the kit.

Hot water pipes in unheated parts of the house should also be insulated to further reduce heat loss and improve the overall efficiency of your water heating system.

C. Drain Sediment from the Water Heater

Over time, sediment particles normally found in water will settle to the bottom of the water heater. This sediment will insulate the water heater from the heat source, requiring more energy to heat the water. Once or twice a year the sediment should be drained by opening the water heater drain valve and



Simple, Inexpensive Ways to Save Energy

allowing one to two gallons of water to drain out into a pail. (Many water heater drain valves are threaded so that you can also attach a hose and drain the water directly into a floor drain or sink.)

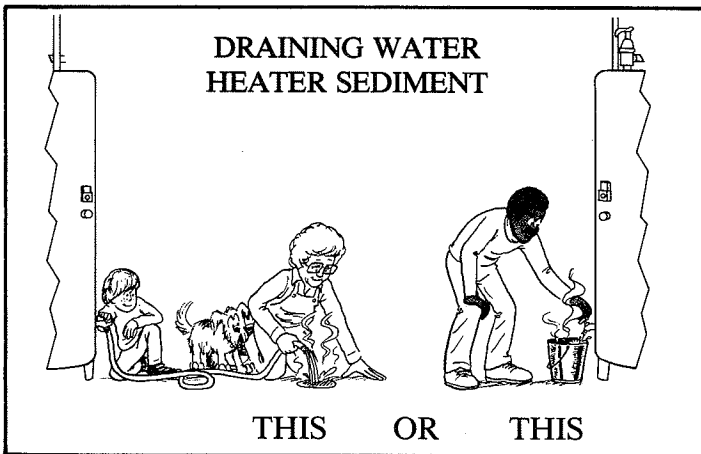

D. Using Water Flow Restrictors and Low Flow Shower Heads

Reducing the amount of hot water you use will reduce your energy expenses. Flow restrictors and low flow shower heads can reduce the water flow from 5-6 gallons per minute to 2-3

gallons per minute. An average ten minute shower using a low flow shower head requires about half as much water as a conventional shower.

Flow restrictors and low flow shower heads come in a variety of sizes and styles to fit most plumbing fixtures and can be purchased at most hardware stores. When purchasing a low flow replacement, take your existing plumbing fitting with you to make sure the one you buy fits your faucet or shower.

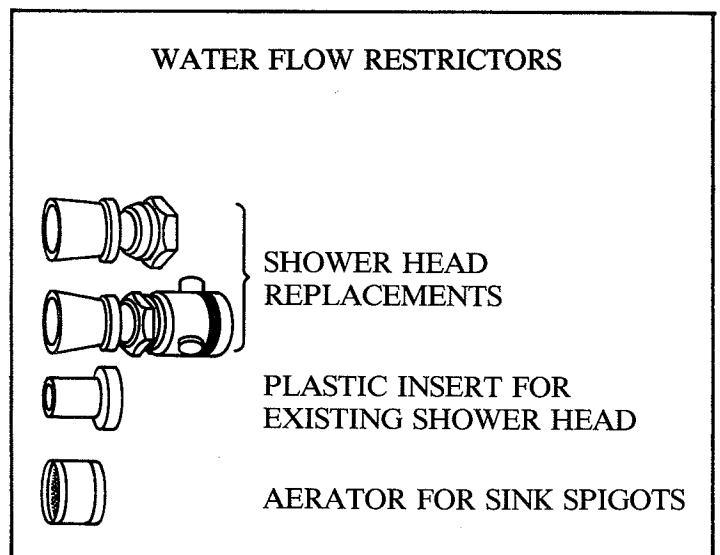



Reducing Air Leaks and Heat Loss

Reducing air leaks and preventing heat loss through roofs, walls, floors, windows, and doors are among the greatest challenges to conserving energy in older homes. This chapter provides suggestions to reduce air leaks and heat loss in those areas that are major sources of energy waste. Recommendations pertain mostly to insulation, weatherstripping, and caulking. For the most part, these procedures are much the same as those used for newer homes. Other sources of information are noted later in this chapter.

IF YOU'RE DOING THE JOB YOURSELF, THINK SAFETY FIRST

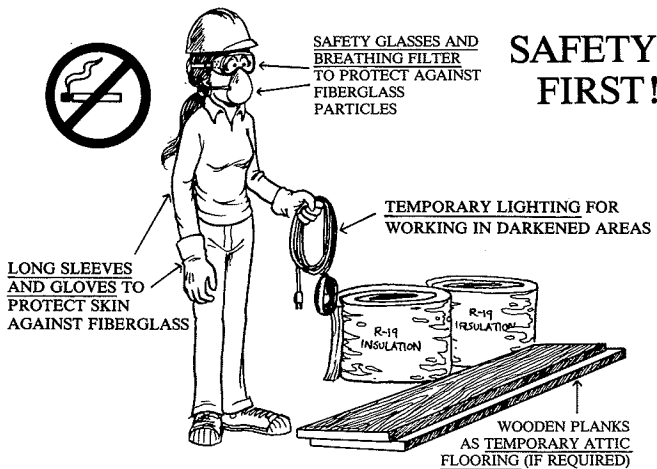

a combination of batt insulation and, in hard-to-reach spaces, blown insulation. Even if the attic has sufficient work space, it is probably floored and used for storage, further complicating an insulation job.

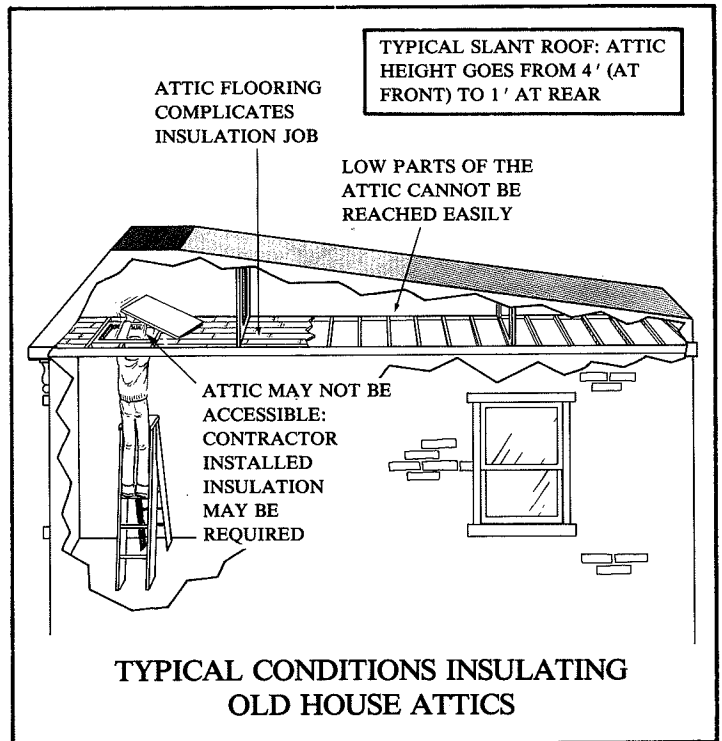

1. Attics



Because warm air rises, the attic is one of the most important parts of the house to insulate. In many older homes, attics are not insulated or are underinsulated because typical builders and homeowners before 1940 were not very concerned about energy conservation.

Regardless of the shape of the roof—flat, slanted, or topped with an ornamental peak—accessibility is the basic problem to insulating old house attics. Many flat and slant roof row-houses have only 1-3 feet of space above the upper ceiling, and often access is limited. Other houses with odd-shaped or low slanted rooftops have only partial access, and may require

A. Insulating the Attic

- For a slant roof row house attached on both sides having no access door to the interior attic crawl space, insulation may be difficult and expensive. An access door to the attic can be made by cutting through the ceiling, usually in an inconspicuous spot such as inside a closet. The last resort would be to install insulation on the roof exterior (refer to part C of this section, p. 21). Estimates and opinions from qualified contractors may help you decide.
- In any attic with no insulation, add the R-value for your region of the country specified in Section B, p. 20.

R-Value is the measure of the insulating value of a material. A higher R-value means a higher insulating ability.



Reducing Air Leaks and Heat Loss

MEASURING EXISTING LEVEL OF ATTIC INSULATION

1 INCH INSULATION = APPROXIMATELY R-3

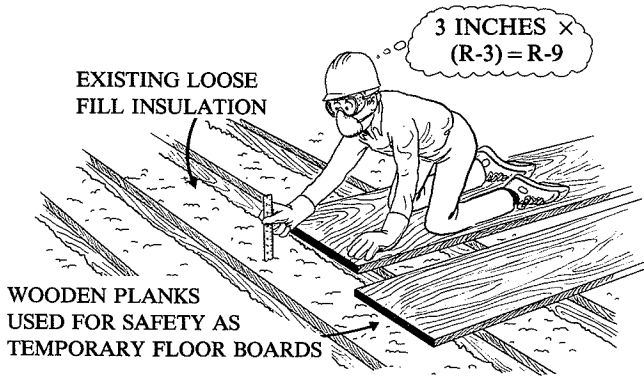

- If there is insulation and the R-value is not known, assume a value of approximately R-3 for each inch of existing material. Compare this with the recommended R-levels in Section B. Generally speaking, it is not economic to add less than six inches (approximately R-18) of insulation. If you already have 4 inches of insulation (R-12) and you need R-19 for example, it probably won't pay to invest in an additional 2 inches. As the price of energy continues to rise you may wish to check with a specialist or your local utility company or fuel oil dealer to help determine at what price more insulation becomes economical.

B. Insulation Required

The amount of insulation required depends upon the location of the house. The map indicates how much insulation should be installed, depending on the type of fuel used for heating. The charts can be used also for determining minimum wall and floor insulation needs. If the attic is not accessible or partially accessible, estimates from insulation contractors on additional installation costs may affect your decision to install attic or ceiling insulation.

RECOMMENDED INSULATION LEVELS

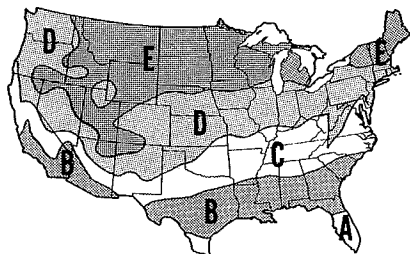

RECOMMENDED INSULATION LEVELS

Table 1. For oil heat, gas heat, or heat pump*

	Climate Zone (see map)				
	A	B	C	D	E
Attics	R-19	R-19	R-19	R-30	R-38
Frame walls	none	fill cavity		fill cavity	
Walls of heated basements and crawl spaces	none	none	R-3	R-11	R-11
Floors over unheated spaces	none	none	R-11	R-11	R-19

Table 2. For electric resistance heat*

	Climate Zone (see map)				
	A	B	C	D	E
Attics	R-19	R-22	R-30	R-30	R-38
Frame walls	none	fill cavity		fill cavity	
Walls of heated basements and crawl spaces	none	none	R-6	R-11	R-11
Floors over unheated spaces	none	R-11	R-19	R-19	R-19

*"Recommended" levels are based on the May 1979 revisions to the HUD Minimum Property Standards.

Reference: *The Energy-Wise Home Buyer - A Guide to Selecting an Energy Efficient Home*, HUD, September 1979. HUD-PDR-412(2).

C. Insulation Options

- **Materials.** If access to the attic is available and there is sufficient work space, foil-backed batt insulation is appropriate

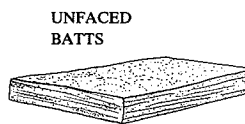
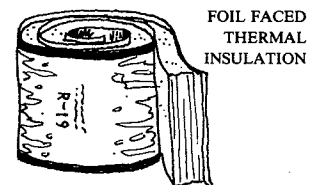

UNFACED BATTs

where there is no existing insulation. If there is existing insulation, use unfaced batts. Loose-fill insulation can be used also. (If there is no existing insulation, a suitable vapor barrier should be installed first.) Blown loose-fill insulation is particularly appropriate in attics with limited space or limited access. If there are special problems with difficult-to-reach attic or roof spaces, a professional may be needed to advise you about your attic insulation needs.

LOOSE-FILL THERMAL INSULATION

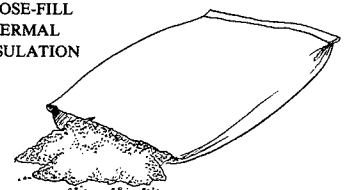



- **Beyond the Attic.** Where appropriate, caulk or apply roof cement around window dormers, air vents, and chimneys. Repair roof surfaces to avoid leaks in the attic, for moisture entering through these openings will reduce the effectiveness of attic insulation as well as cause structural damage. If a leak is suspected, check the attic during a rain storm.

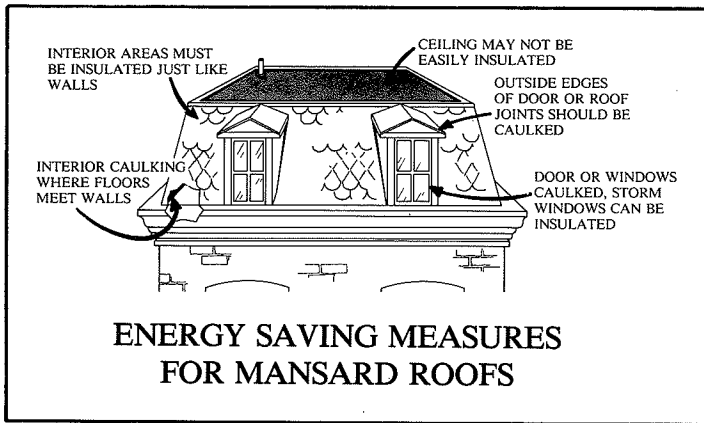

- **The Last Resort.** When installing attic insulation on the interior is impossible, rigid board insulation may be used on the outside surface of roof area during major home improvement or renovation to the existing roof. This method is appropriate for houses with cathedral ceilings. However, do not install the insulation above a vented attic or vented rafters or trusses.

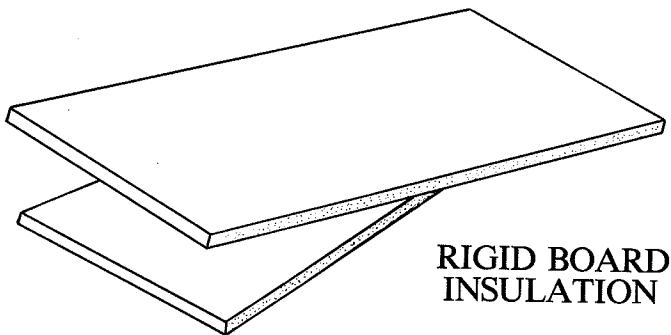

D. Installation Cautions

- Be sure not to block ventilation openings (soffit vents) around the edges of the roof when installing insulation.
- Vapor barriers are designed to keep moisture away from insulation and are installed on the warm-in-winter side of the insulated space.

CAUTIONS FOR INSTALLING ATTIC INSULATION

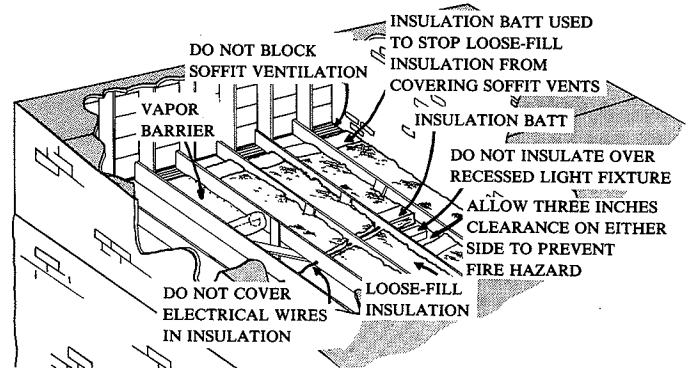

- Do not insulate within three inches over and around any existing light fixtures. When using loose-fill insulation, use pieces of batt insulation near the fixtures as a barrier to maintain the required clearance.

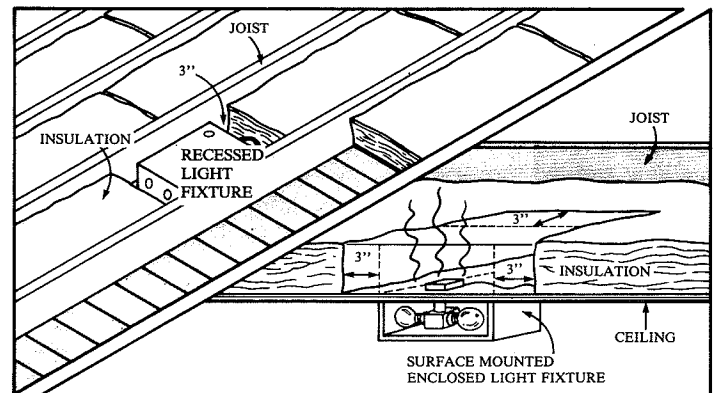

INSULATING AROUND RECESSED AND ENCLOSED LIGHT FIXTURES (INSULATION BATTS)

- Do not sandwich wires between insulation batts because wires may overheat and cause a fire. Wires are best left above insulation.
- When working in unfloored attic spaces, use boards for walking to prevent falling through the ceiling.

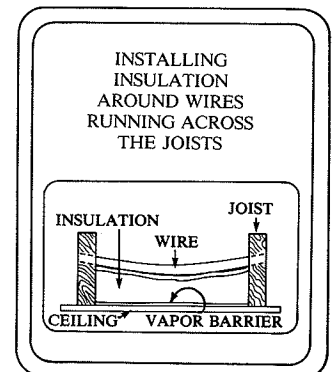



Reducing Air Leaks and Heat Loss

- Check loose-fill insulation after installation to ensure that it does not shift because of air movement in the attic. Cover with chicken wire, if needed, to prevent shifting.
- When replacing flooring over plaster ceilings, use screws or glue instead of nails to prevent cracking and damage to ceilings.



2. Walls

Wall construction of older homes falls into two general categories: masonry or frame construction. Each type presents special insulation problems. In a semi-attached or attached townhouse or rowhouse, insulation will not be required for walls adjacent to other buildings. In a corner unit, wall insulation may be a good idea, but your decision should be made subject to conditions discussed later in this section.

Compared to other conservation measures, wall insulation generally is a lower priority than pipe and duct insulation, caulking and weatherstripping, attic insulation, storm windows, and clock thermostats.

A. Masonry Walls

Masonry walls usually have a double layer of brick with plaster applied directly having no airspace between the plaster surface and the exterior bricks. Where there is no airspace, plaster-on masonry can be insulated only by "furring out" the interior walls, or building a new interior wooden wall frame, then applying rigid insulation board and rebuilding the interior walls using gypsum board. This is an expensive, difficult, and messy process and should not be considered unless major restoration or modernization

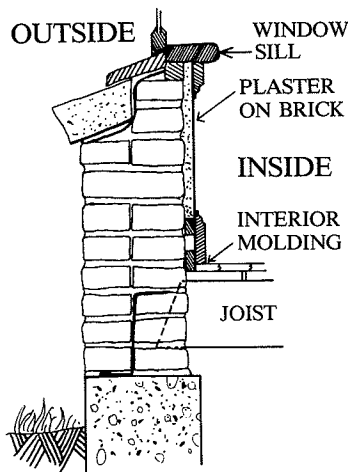

EXISTING 10" WALL,
CROSS SECTION
OF TYPICAL
MASONRY WALL

is being done. For the most part, there is very little that can be done to insulate these old home masonry walls.

In those masonry walls where a very narrow cavity exists, it is not cost-effective to install insulation because the small amount of insulation installed would not improve significantly the thermal quality of the wall. Do not be overly concerned about insulating these walls.

If the exterior masonry walls show signs of serious deterioration such as cracking and loose brick or crumbling mortar, professional repointing (replacement of old mortar) may be required to prevent air and moisture seepage into interior walls.

B. Frame Walls

Wood frame homes normally have empty wall cavities. Usually the wood framing is covered by plaster over lath or gypsum board on the interior, and wood shingle, clapboard, or brick facing on the outside. Some older homes, however, have been modified with aluminum or vinyl siding.

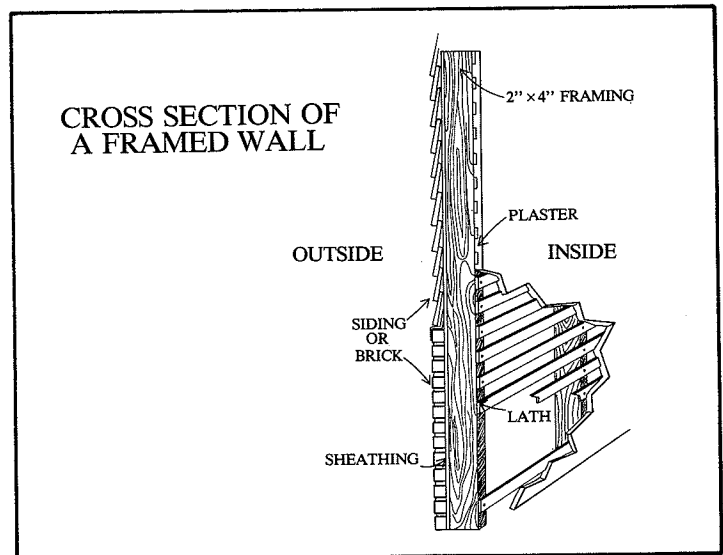

Wall insulation can reduce heat loss by up to two-thirds and can reduce heat gain in summer. Dry cellulose insulation or loose-fill mineral fiber insulation—both installed by a contractor—may be used. Settling and shrinkage of cellulose and some foam insulations, however, may reduce the effectiveness of these materials over time. A satisfactory solution to this problem has not yet been developed.



A decision to install wall insulation should be weighed very carefully against other possible conservation purchases that may provide greater energy savings. Contractors should be consulted for opinions and estimates about insulation materials and their cost-effectiveness. Contact your state and local consumer organizations or energy office for details about the different wall insulation products currently on the market in your area.

Some special concerns about insulating old frame homes are listed below.

- **Behind the Wall.** Many older frame houses were built with 'balloon framing', where wall studs go uninterrupted from the foundation sill to the roof rafters. Openings at the foundation sill need to be sealed to prevent blown-in insulation materials from spilling out during installation.

INSULATING A BALLOON FRAME WALL (CUTAWAY VIEW)

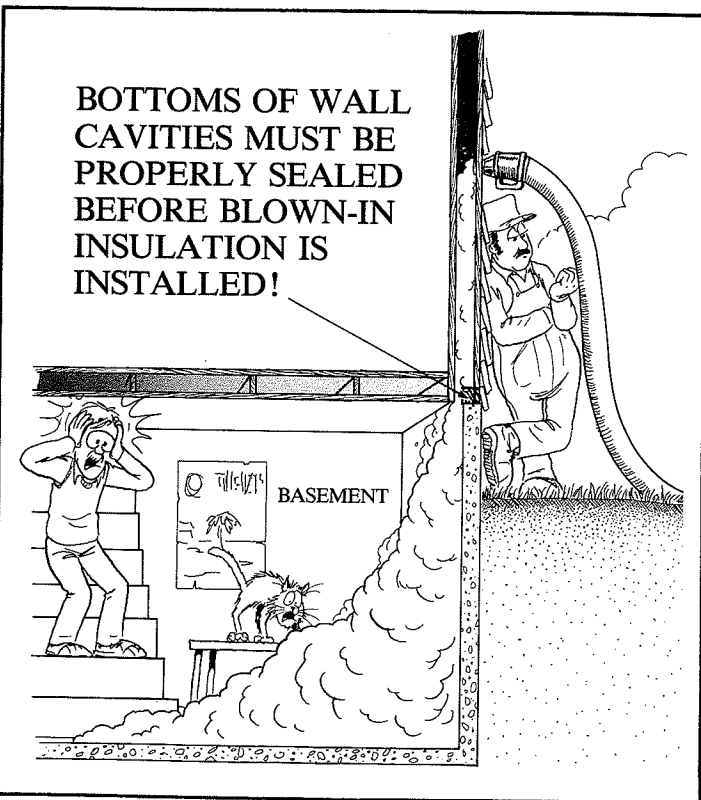
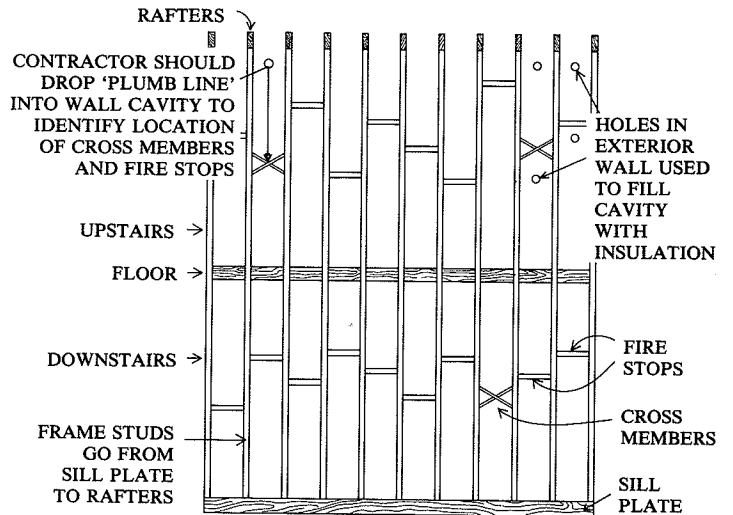

Also, fire stops and cross members between wall studs need to be identified, otherwise blown-in insulation will not fill the height of each cavity. This should be done routinely by an insulation contractor.

- **Window Sash Boxes.** Old style windows were designed with rope or thin chain attached to weights recessed in the walls on each side of a window. Enclosed inside a sash box, the weights were designed to keep the top sash from slipping into an open position and to keep the bottom sash from slipping closed after the window is opened. Sash boxes can interfere with adequate insulation in walls around the window area. Blown-in insulation could affect the proper functioning of the windows. If your windows are sash box-type, make sure to ask your insulation contractors about their experience dealing with sash box windows. If the windows have been replaced, eliminating the need for sash weights, the sash boxes should be filled with insulation when the walls are insulated.

Older windows with sash weights complicate insulating walls.

If loose fill insulation is allowed into sash box, window may not function properly.

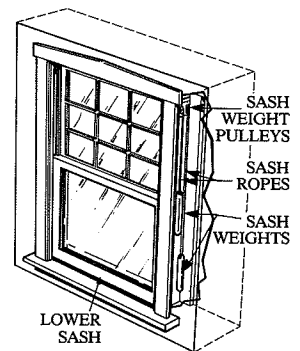



Reducing Air Leaks and Heat Loss

- Interior Vapor Barrier.** Air normally flows freely within uninsulated frame walls, which helps evaporate inner-wall moisture. Blown-in insulation greatly reduces this natural air flow, leading to a possible build-up of condensation behind the wall. A vapor barrier on the interior wall may be required to keep moisture away from the insulation. A plastic or foil wall covering can be used as a vapor barrier. Vapor barrier paints are also available.

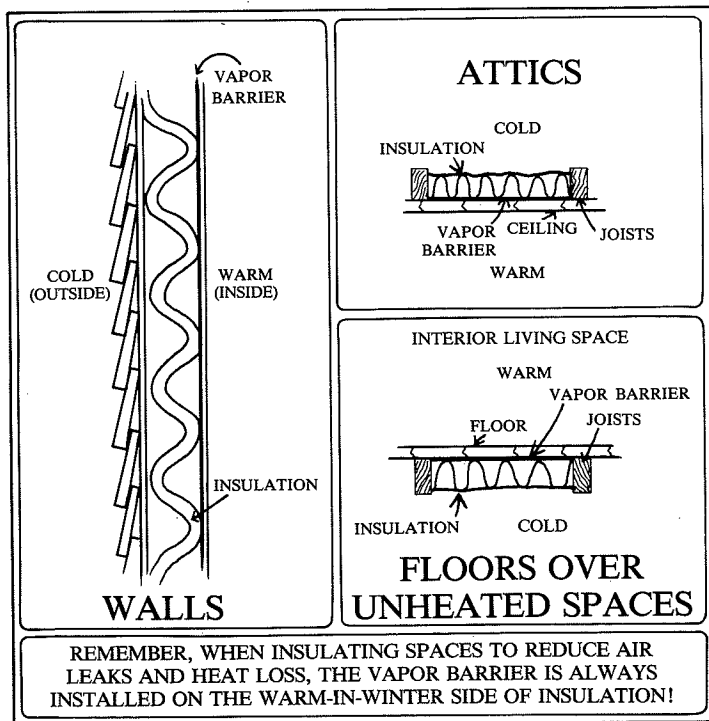

C. Caulking Masonry and Frame Houses

Wherever two different building materials on the exterior come together, there may be gaps causing air leaks and heat loss. All window and door frames, corner joints, and chimney joints should be caulked.

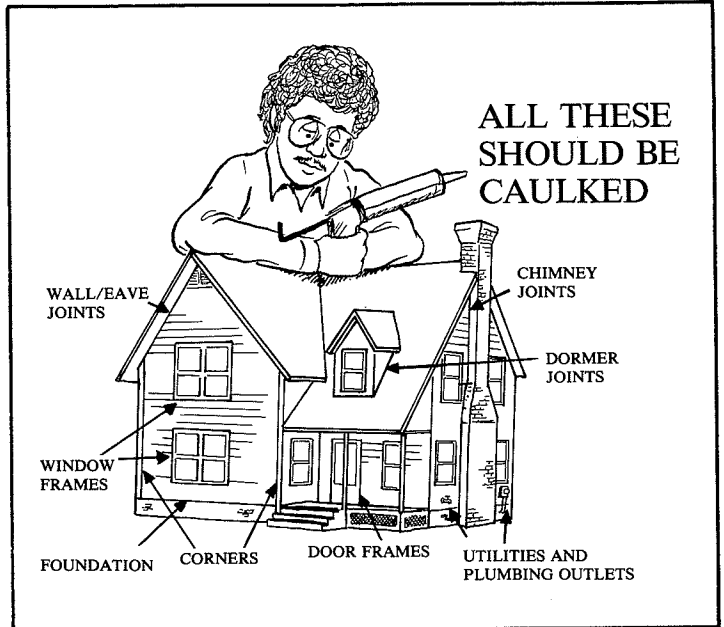
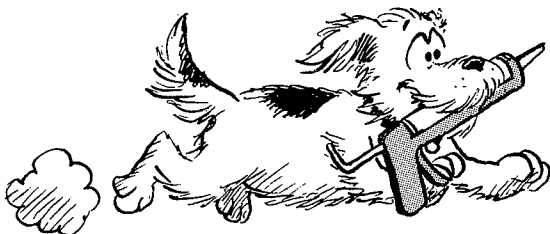

Interior caulking can be equally important. It helps reduce heat loss where walls meet other interior surfaces such as window sills and door frames, where pipes and ducts enter walls, and behind baseboards where walls meet floors. Interior caulking also helps reduce inner wall condensation by preventing the inside heated air from contacting cold exterior walls.

INTERIOR CAULKING HELPS PREVENT AIR LEAKS AND HEAT LOSS THROUGH CRACKS AND GAPS IN HOUSE STRUCTURE

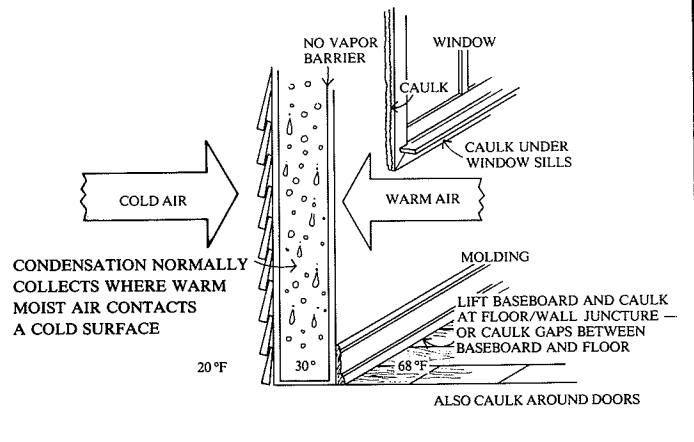



3. Floors and Unheated Spaces



The ground floors of many old houses were constructed over unheated cellars, half-basements, crawl spaces, or other sub-surface dugouts such as cold storage. Often these areas are damp and drafty, and actually draw heat away from living spaces. It is important to insulate the surfaces adjacent to these spaces through which valuable warmth is being lost. If the unheated area beneath the floor is accessible, then insulation and a ground cover vapor barrier should be installed. In some old homes, these unheated areas are completely inaccessible because of the way the foundation is enclosed or because there is very little space between the ground and the floor joists. If the foundation space is inaccessible, then alternatives such as installing carpeting and a thick under-pad on the interior floors above the unheated space can be used to reduce heat loss through the floor.

A. Installation

If the basement or crawl space is unheated, insulation batts should be installed between the floor joists. The insulation should cover any pipes running parallel or perpendicular to the floor joists, so these will not freeze. However, insulation batts will not remain in place under a floor unless some support is provided. Chicken wire stapled or nailed to the joists can be used, or nails set along the joists can be laced with wire to keep insulation in place. Spring wire clips made for this purpose can also be used. Insulation should include a vapor barrier installed toward the heated part of the house.

INSTALLING UNDER FLOOR INSULATION

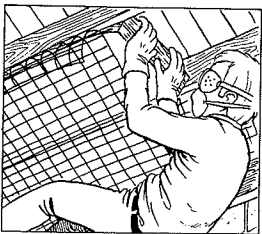

CHICKEN WIRE SUPPORT USED

OR



LACING WIRES ON NAILS SET INTO JOISTS

B. Ground Cover Vapor Barrier

When installing insulation in a crawl space, a ground cover vapor barrier also should be installed to reduce moisture in

the crawl space. A six-mil thick polyethylene sheet, held in place with bricks along the perimeter wall, can be used.

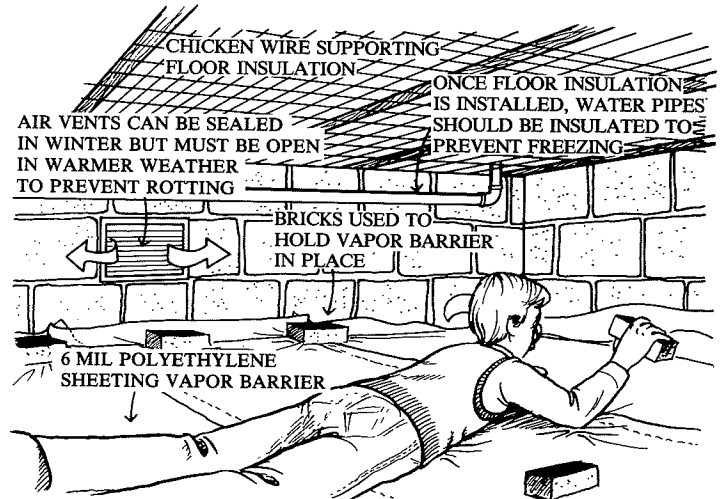

C. Ventilation in Unheated Foundation Areas

If the crawl space is accessible, vents can be closed in cold weather but should be open in warm weather to prevent the rotting of wood under the house. If there is no access to the crawl space, don't worry about adjusting the vents.

D. Perimeter Wall Insulation

Insulating basement walls, particularly the parts that are above ground level, will help prevent heat loss. Batt insulation installed between wall frame studs is appropriate if the basement is to be panelled. If possible, place insulation between the outside walls and pipes to keep them from freezing. If you decide to use rigid foam board insulation, 1/2 inch gypsum board should be used to completely cover the insulation.

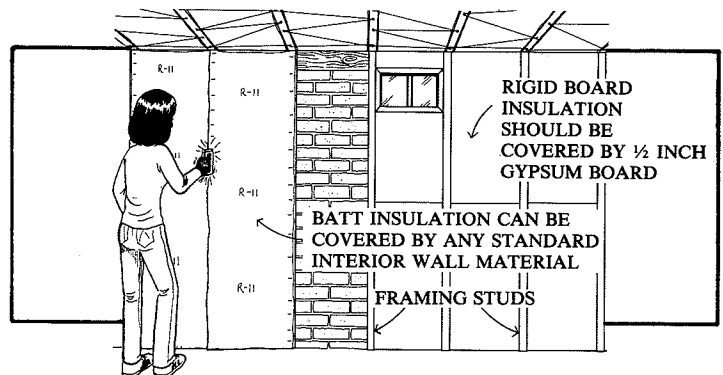



Reducing Air Leaks and Heat Loss

E. Insulated Floors—Frozen Pipes

Remember that under-floor insulation is designed to keep heat in the house, so the crawl space will be considerably colder once under-floor insulation is installed. Any pipes previously kept warm by heat escaping through the floor may be subject to freezing. Therefore, crawl space water pipes should be insulated and, in extremely cold areas, may need to be protected by a heat tape. Heat tape is an electric wire device that is wrapped around the pipe to keep it from freezing. A qualified insulation contractor should be consulted to determine if and how much heat tape needs to be installed in your area of the country.



4. Windows

Energy problems related to windows are substantial because older windows tend to be large (many are five feet or more tall), and drafty, particularly if they have not been properly maintained. Unlike contemporary double hung wood frame windows mounted in close-fitting aluminum tracks, older wood-frame windows tend to fit loosely in their wooden tracks. These can be a major source of heat loss and air leakage.

Metal casement windows, which were first manufactured early in the 20th century, are problematic. First, their metal frames often do not make a tight seal when the window is closed. Second, casement windows that are installed into masonry leave hard-to-seal gaps between the brick and window frame. Third, interior condensation over time can rust the window casings and deteriorate the window's seal.

Many of the standard weatherstripping, caulking, and storm window solutions for contemporary windows are appropriate for older windows. Casement windows present some special problems but a combination of proper maintenance and the application of specific solutions can help prevent uncomfortable and costly drafts and heat loss. This section identifies appropriate solutions for windows currently found in older homes.

A. Basic Energy-Conscious Maintenance

- **Glazing and Putties.** Broken or cracked window panes should be replaced. Aged glazier's putty, which is cracked or missing, also contributes to heat loss.

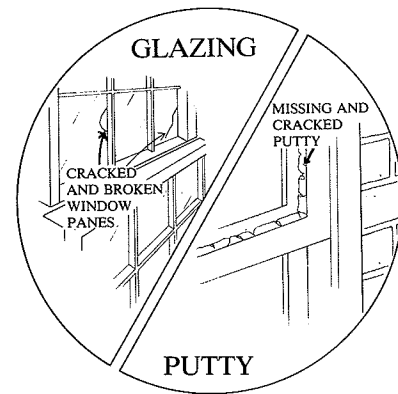
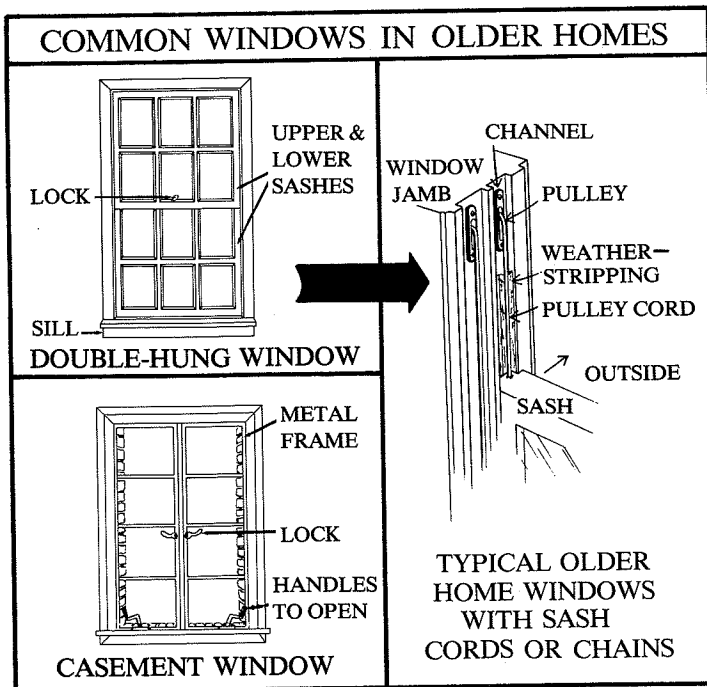

Replacement of both glazing and putties are easy, inexpensive measures to improve comfort by decreasing drafts through windows.

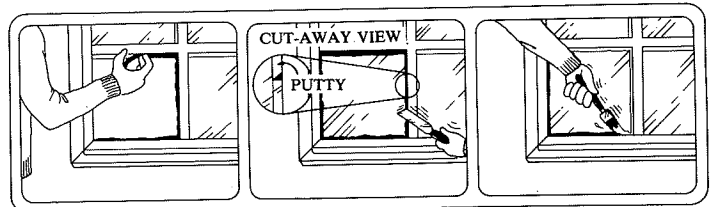

- A. PUT PUTTY IN FRAME B. PRESS PUTTY AROUND EDGES AND SMOOTH WITH PUTTY KNIFE C. ALLOW ONE WEEK TO DRY, THEN PAINT PUTTY



- Weatherstripping and Caulking.** Weatherstripping seals air spaces and gaps on window frames and sashes. Weatherstripping should be installed around the window frame and along the width of the rails. Caulking should be applied to the exterior and interior of the window frame. Caulking also can be applied around the window sashes if the window is to remain closed permanently.

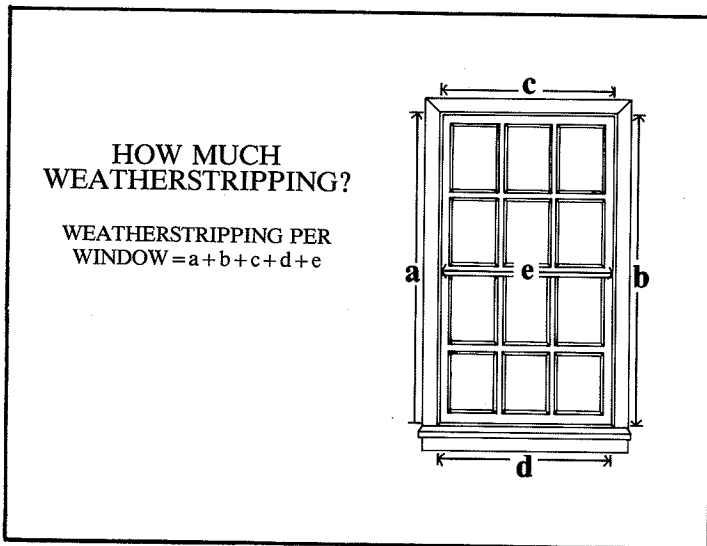

- Casement Windows.** Metal casement windows require special consideration to seal them against heat loss and air leaks. Metal framing should be de-rusted with a metal brush to ensure the seal is as tight as possible. Locks, too, should be secure and rust free. The handles should be oiled and should fit tightly in their seats, so the window can be drawn tightly closed. All casement windows should be checked periodically, especially in the winter when condensation tends to collect, deteriorating the window. Paint build-up also may inhibit proper closing, and the window frame may need to be stripped or cleaned with a wire brush.

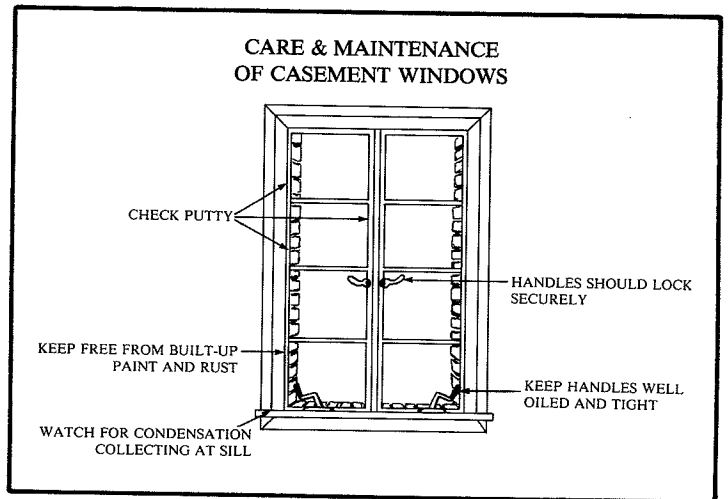

WEATHERSTRIPPING			
TYPE	SPRING METAL	ROLLED VINYL	FOAM RUBBER AND FELT
INSTALLATION	SOMEWHAT DIFFICULT	EASY	EASY
DURABILITY	GOOD	GOOD	POOR

- New Hardware for Old Windows.** Many 19th century frame windows were installed without locks, which help to seal windows tightly. Improper installation of new locks on old windows also can force windows apart. Check to make sure that all hardware has been installed properly.

B. Storm Windows

- Triple Track Storm Windows.** Many old houses still use the original custom-built, wood frame storm windows and screens that must be removed seasonally. Triple track storm windows, with two sliding glass sashes and one sliding screen sash, are the most versatile for wood frame windows. These windows provide protection against cold in winter, but in summer they can be opened for natural ventilation. Unfortunately, storm windows for large size or odd-size old home windows are costly. If you cannot purchase storm windows for the entire house at once, the selective application of storm windows may help reduce the most serious of your home's window drafts. In particular, north-facing windows need to be protected from cold winds that steal heat from your house. Check with your local utility company for help calculating how long it will take for the value of energy saved to equal the



Reducing Air Leaks and Heat Loss

initial expense of storm windows. Knowing this “payback” period will help you make a more informed decision about purchasing storm windows.

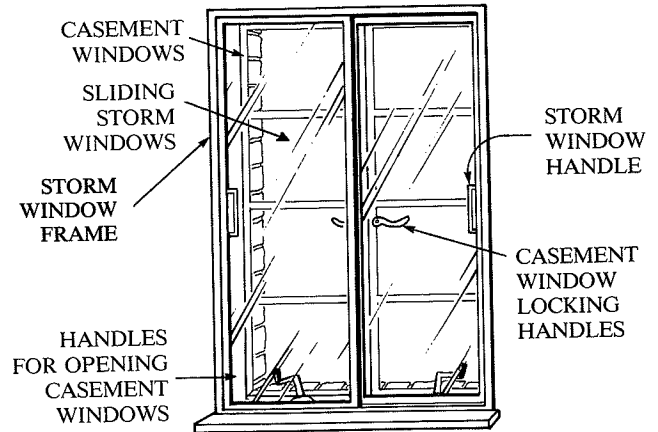
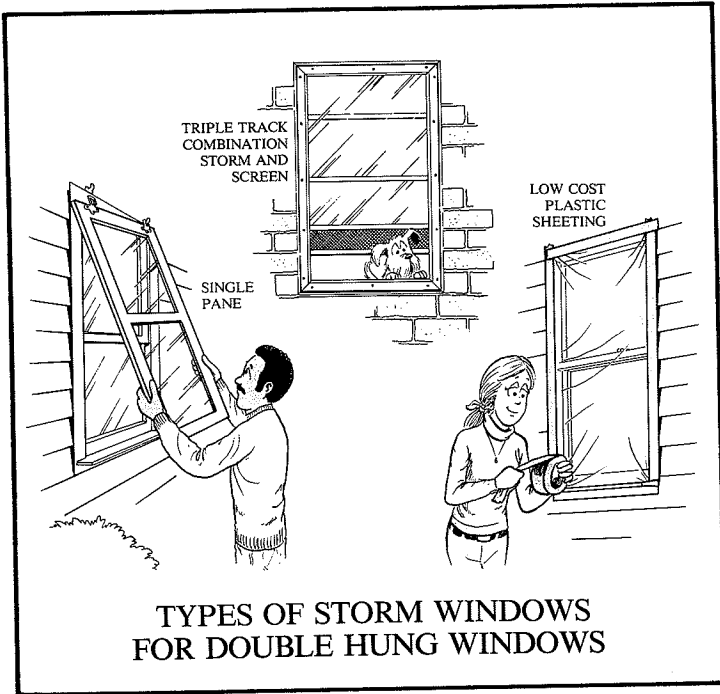

Single pane or horizontal sliding windows can be used. If the cost of installing casement storm windows is prohibitive, there are some easy, inexpensive methods of creating temporary, low-cost plastic storm windows.

- **Low-Cost Plastic Storm Windows.** Rigid plastic storm windows can be bought and assembled or can be cut to fit each window and taped to the outside or the inside of the window frame. The windows are clear, reusable, and relatively inexpensive. Plastic sheeting, usually 6 mil polyethylene film, also can be taped directly to the window frame. While this definitely helps reduce heat loss, there are some special considerations.

- The plastic must be replaced each year.
- Some plastic is not clear and obstructs the view. (Clear polyvinyl is a good material to use.)
- the duct tape adhesive may loosen.

- **Single-Pane Storm Windows.** Many old homes still have the original single-pane windows that are hooked to the outside of double-hung windows. The storm window is installed for the heating season and is replaced by a wood-frame screen during the summer months. These windows can be cumbersome to handle and require lots of storage space, but they do add some character to your house. If you don't have the original storm windows, you may want to have these custom built for your house.

- **Storm Windows for Casements.** Because casement windows swing out when opened, standard storm windows cannot be used. Storm windows for casement windows function differently, and should be installed on the inside of the house. These storm windows allow access to the casement window handle so the window can be operated freely. Exterior casement storm windows are designed to fit onto each of the moveable window sections, but these do little to stop the air leaks along the poorly sealed edges of the window's metal frame.

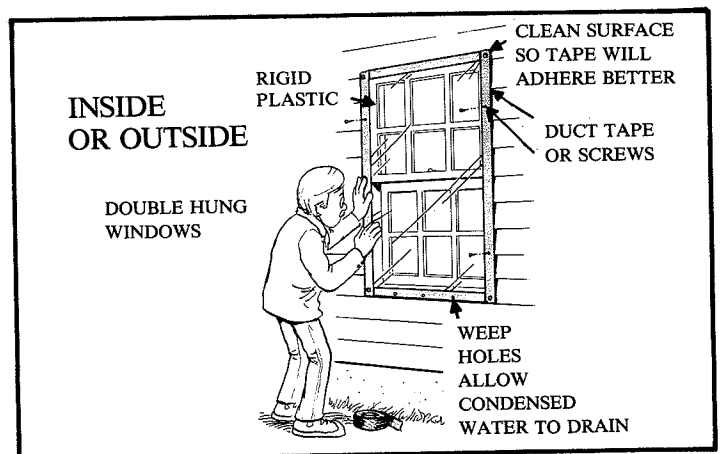

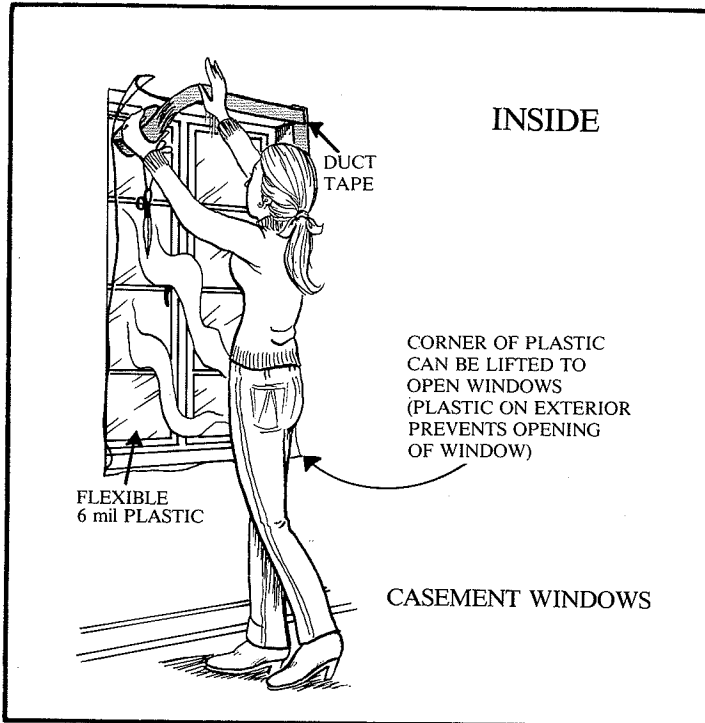

C. Glass Set in Lead

Glass windows with panes fitted together individually in lead channels are another source of heat loss. Over time, gaps around the edges of small and irregular glass pieces can develop and should be sealed. If these windows leak, one solution is to fasten, with screws, rigid plastic sheets on the inside pane of the window. Also, a silica gel (available in hobby stores where stained glass supplies are sold) can be used to fill gaps around lead channels where the glass pieces join.

D. Shades and Shutters

Even after weatherstripping your windows, caulking all the cracks, and installing storm windows, your windows still may be drafty. Insulated or thermal shades and shutters are becoming increasingly popular. When tightly fit, they insulate the entire window space from summer heat gain and from uncomfortable winter drafts and heat loss. Many varieties of thermal window coverings are available in stores, or they can be custom made by any reasonably handy person. For old homes, in particular, thermal shades and shutters may provide one good solution to large or odd-shaped drafty windows.

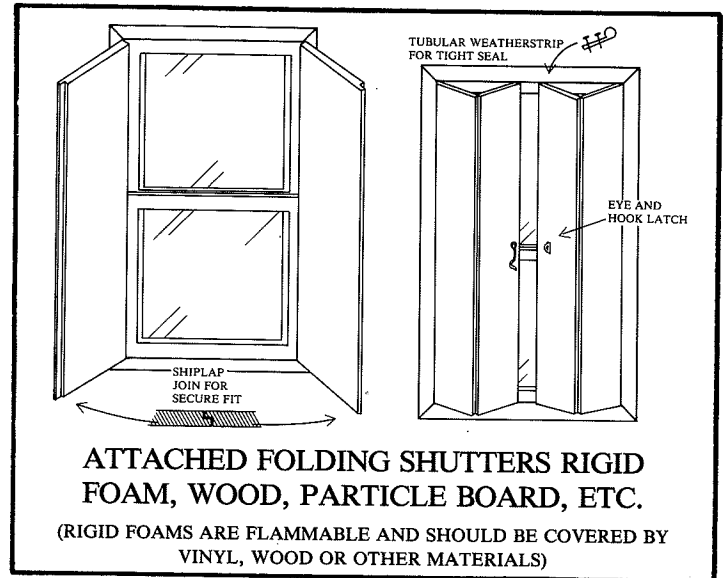

E. Awnings

Sunshade overhangs and awnings can be used effectively to prevent more than 70 percent of summer sun from entering your home. Energy savings attributed to awnings vary with the type of awning and the type of home construction.

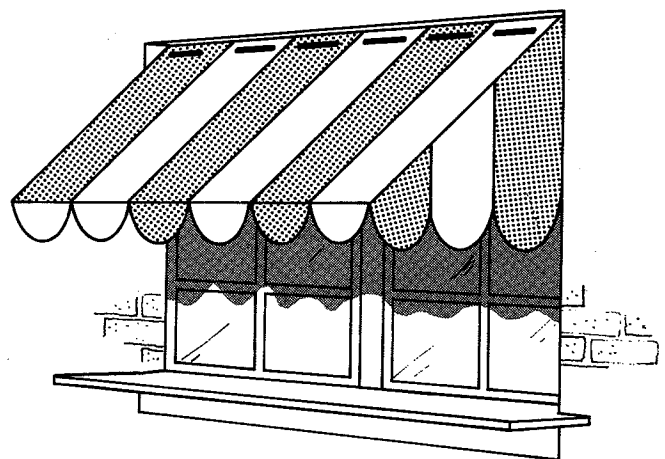

CONVENTIONAL
WINDOW AWNING

Metal awnings tend to cost more, but can last the lifetime of a home. Canvas awnings function as well, but they have to be recovered about every 5 to 7 years. Retractable designs are



Reducing Air Leaks and Heat Loss

simple to operate and can remain attached year-round. When retracted, these allow winter sun into windows.

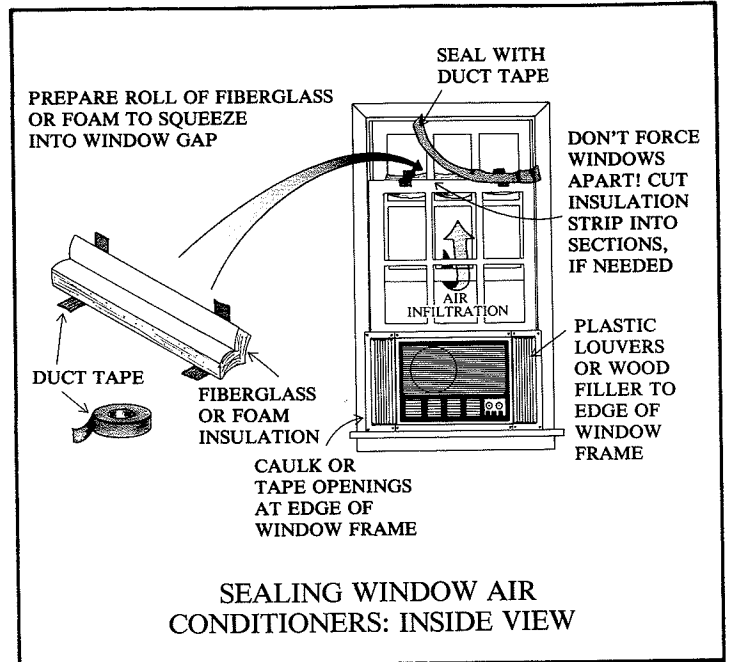
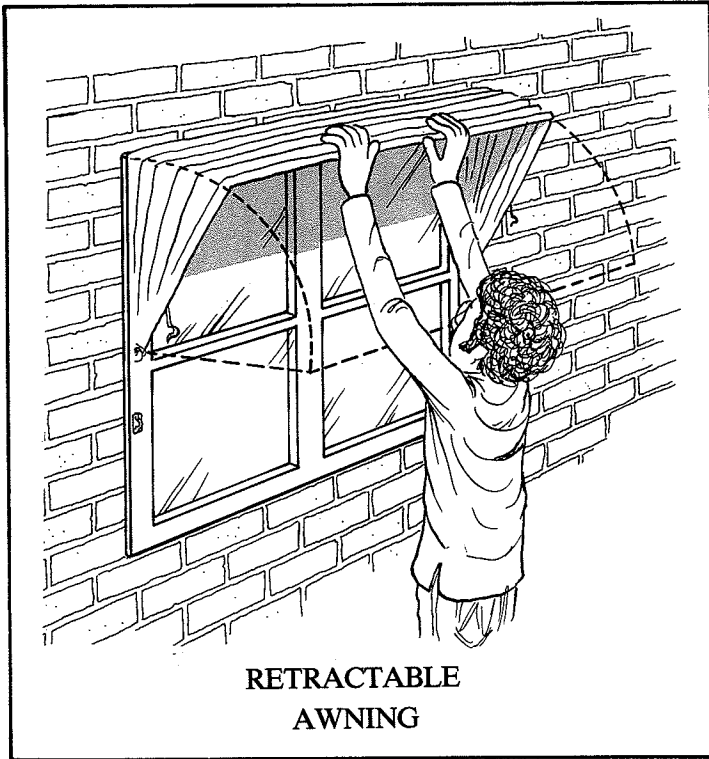

At the beginning of the cooling season when you want to use the air conditioner again, remove the outside plastic cover and throw it away. **DO NOT REMOVE THE INSULATION IN THE WINDOW GAP.** This keeps cool air inside in summer just as well as it keeps hot air inside in winter.

F. Windows with Air Conditioners

Very few older homes have central air conditioning, so many people use standard window air conditioning units. In winter, the air conditioner should be removed, if possible, so the window can be closed tightly, otherwise a gap will be created between the window sashes when the window is raised. If, for some reason, the air conditioner is left in the window, precautions should be taken against air leaks and heat loss.

Sealing a window with an air conditioner is an inexpensive, relatively simple task requiring plastic sheeting, duct tape, and a width of foam or batt insulation. A roll of insulation or strip of foam the width of the window can be used to seal the open gap at the top of the inside window. Gaps and cracks on both sides of the air conditioner should be sealed with tape or caulking. The air conditioner should be wrapped tightly on the outside with 2 to 6 mil plastic to reduce any air leakage into the house through the body of the air conditioner.

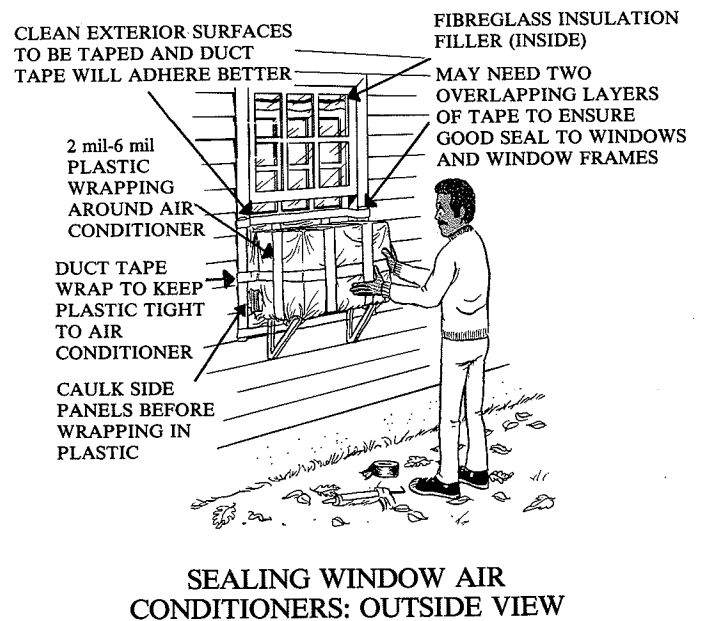



5. Doors

Like windows, the doors of your home are prone to heat loss and air leaks. However, most doors on older homes are not much different from those on contemporary homes, so the basic methods for tightening them and reducing drafts are similar. One major problem to look for is the condition of the door threshold, which may become worn from years of foot traffic. If there is a significant gap between the door bottom and the worn threshold, replacement or repair of the threshold will be necessary to reduce energy waste.

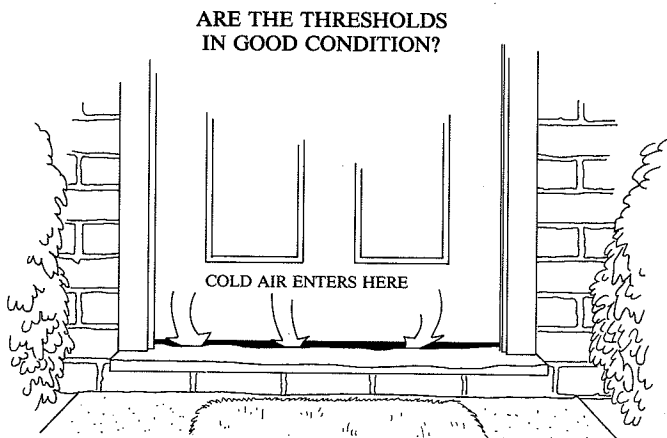

This section highlights some of the basic techniques that can reduce air leaks and heat loss through doors.

A. Basic Maintenance

- **Weatherstripping.** Rolled vinyl, foam rubber, felt, or spring metal weatherstripping should be installed around edges where the door meets the frame. The bottom of the door should be fitted with a door sweep, which is a metal strip with an attached felt or rubber gasket, provided it does not already have an energy-conserving threshold (one that interlocks or has a rubber gasket that seals tightly against the door when it is closed).
- **Windows Within Doors.** Windows in doors, whether stained glass, leaded glass, or plain glazing, should be treated like any other window. Replacement putty or caulking should help seal leaks. Special instructions for

insulating stained and leaded glass are described in Section 4(C) of this chapter.

- **Replacement Thresholds.** If the threshold on a door is worn, an aluminum “saddle” that bridges the existing threshold can be installed to seal the gap beneath the door.

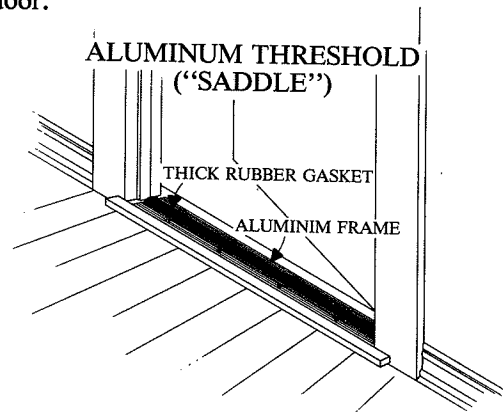

These saddles generally have a replaceable, heavy-duty vinyl insert that seals tightly against the door when it is closed. If the threshold is too worn and needs to be replaced, the job will have to be done by a person familiar with carpentry.

REMOVING OLD THRESHOLD

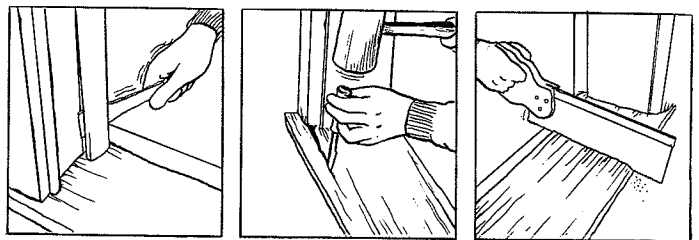

CARPENTRY EXPERTISE IS REQUIRED
TO REPLACE A THRESHOLD. THE JOB MAY
BEST BE LEFT TO A PROFESSIONAL.

INSTALLING NEW THRESHOLD

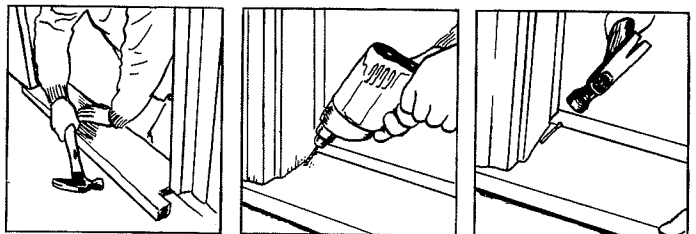



Reducing Air Leaks and Heat Loss

B. Specialty Doors

- **Specialty Doors.** Some old homes have double-closing French doors with glass or louvers. Dutch doors also are common on certain styles of older homes. Both of these double-door styles should be weatherstripped like any other door, though additional weatherstripping will be needed where the two doors meet.

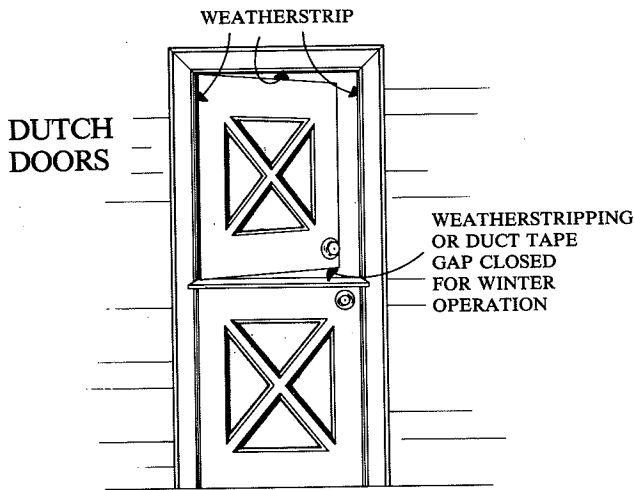

- On French doors there is a wooden overlap molding that blocks the gap between the two doors. Felt or foam weatherstripping can be added on the inside of the molding to prevent air leaks between this gap in the doors.

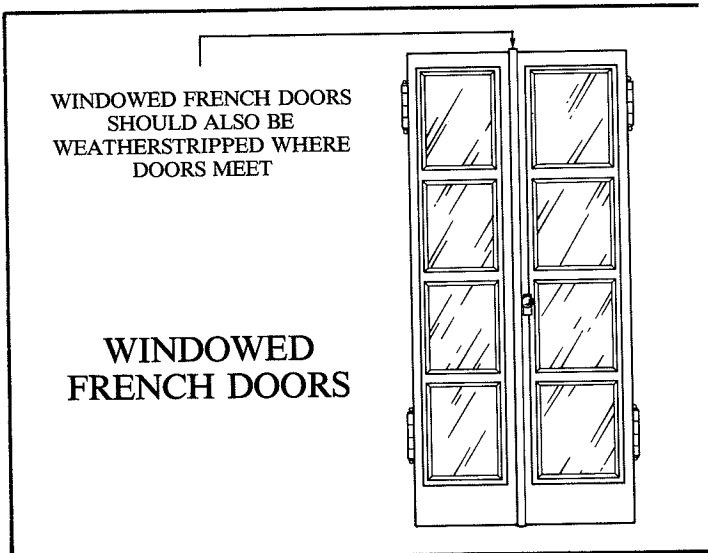

- Louvered French doors can be improved by adding rigid plastic sheets behind the louvers. As a permanent addition, rigid plastic sheets should be screwed to the door, rather than taped with duct tape.

WOOD LOUVER FRENCH DOORS

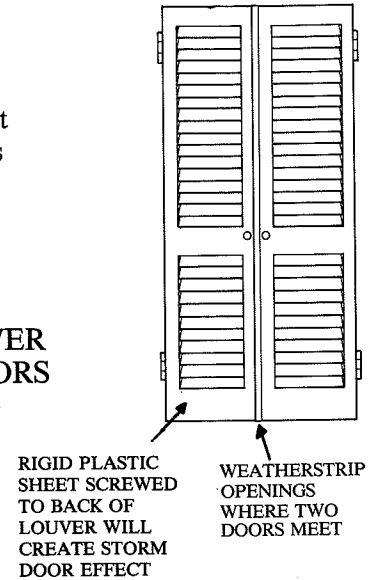

C. More Expensive Items

- **Storm Doors.** Storm doors help reduce air flow through doorways by providing a barrier against wind and drafts. If your home currently has a wooden screen door, you could easily attach plastic sheeting and weatherstripping to the frame to create an effective storm door. With slightly more effort, you could attach a sheet of rigid plastic that could be reused year after year and could be removed during the summer months. Also, combination storm doors, which permit the replacement of screens with glass panels during the heating season, are available with aluminum, steel, or wood frames.

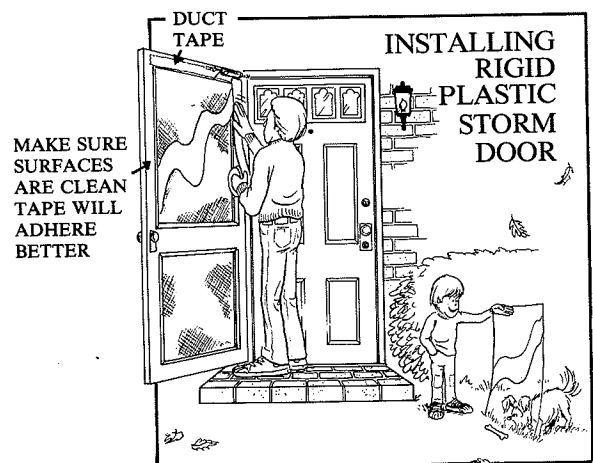



STORM DOOR CAUTION: A well-sealed storm door can behave like a solar collector, whereby the airspace between the storm door and main door becomes very hot if exposed to unobstructed southern sun. Excessive heat may cause the main door to warp or its paint to peel. Heat venting at the top and bottom of the door can be done by removing rubber gaskets or weatherstripping though this will diminish the effectiveness of the storm door. Before installing a storm door on a south-facing door, check to ensure that the door will not have continuous exposure to sunlight.

These are available in a variety of designs and materials to match any home. Replacement doors are relatively expensive items and are worthwhile from an energy perspective if the existing door cannot be sealed adequately.

Other Sources of Information on Reducing Air Leaks and Heat Loss

- **Replacement Doors**

If a door in your home is damaged beyond repair, or if you are contemplating a renovation project, a modern energy conserving door should be considered.

ENERGY EFFICIENT
THERMAL REPLACEMENT
DOOR

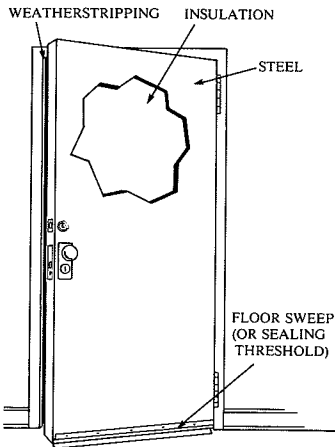

In the Bank . . . Or Up the Chimney? A Dollars and Cents Guide to Energy-Saving Home Improvements, U.S. Department of Housing and Urban Development, October 1977, HUD/PDR-89(4).

The Energy-Wise Home Buyer A Guide to Selecting an Energy Efficient Home, U.S. Department of Housing and Urban Development (in cooperating with the U.S. Department of Energy), March 1979, HUD/PDR-412(2).

From the Walls In Charles Wing, Atlantic Monthly Press, Little, Brown & Company, Boston, Toronto, 1979.

Thermal Shutters & Shades Over 100 Schemes for Reducing Heat Loss Through Windows, William A. Shurcliff, Brick House Publishing Company, Andover, Massachusetts, 1980.



Energy Conservation Opportunities for Mechanical Equipment

The mechanical systems of pre-1940 homes differ greatly from the systems installed in contemporary homes. In addition, the old home heating systems—the equipment and the fuels—have changed dramatically since these buildings were first constructed. For example, 55 percent of all homes used coal or coke, usually to run central steam systems, and nearly 23 percent heated with wood. Today, due to conversions and replacements of old heating systems, almost 60 percent of the remaining pre-1940 housing stock uses natural gas, while about one-third relies on oil. There are, therefore, a variety of heating systems used in older homes, so different kinds of energy conservation techniques are needed to deal with older home equipment. This chapter describes the typical heating, cooling, and ventilation systems found in older homes and identifies appropriate energy conservation opportunities.

1. Radiator Heating Systems



A. Steam Heating Systems

Many older homes have steam heating systems, and many of these original systems continue to function well with little maintenance. Steam heating systems are relatively simple. Water is heated in a main boiler and converted to steam. The steam rises through the pipes to the radiators where it cools, condenses into water, and returns to the boiler through the same pipe. This one-pipe system is typical of almost all residential steam heating systems. Some two-pipe steam systems exist, identified by radiators with a pipe at each end leading to and from the boiler.

Steam system radiators have an air vent valve located at one end, near the top. This vent valve allows unwanted air to escape, which in turn allows steam into the radiator.

Though generally reliable, energy waste in steam systems can be the result of blocked pipes or improper venting. If your steam heating system is plagued by loud pounding or hammering noises, or if some radiators are cold or only partially heated, there are a number of simple things that can be done.

- **Check Radiator Valves.** Radiator valves must be completely open if the radiators are to function effectively.

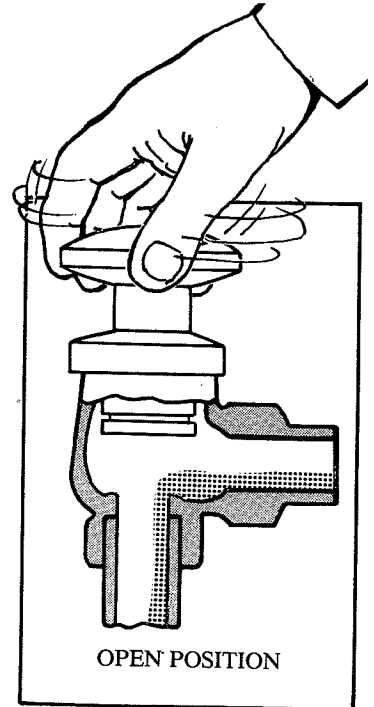
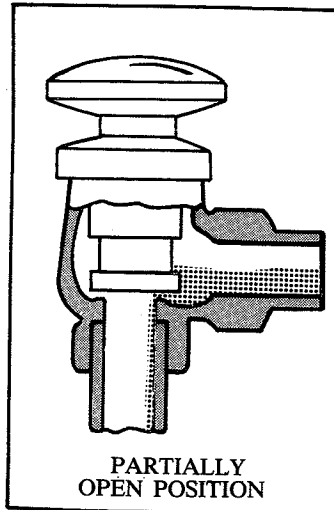

RADIATOR VALVE

Turn each radiator valve counter clockwise, as far as it turns, to allow the maximum amount of steam and water to flow to and from each radiator.

- **Repairing Leaks.** Leaks should be eliminated by tightening joints, pipes, or radiator valves. Before attempting to disconnect pipes to make repairs, be sure to shut off the heating system and allow it to cool. If you're not a do-it-yourself plumber, call a professional to do the job.

Leaking radiator valves often can be repaired by tightening the packing nut. If the leak persists, repair the radiator valve "packing" the same way an ordinary faucet is fixed.

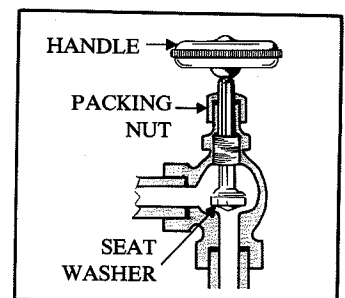

- **Check Radiator Tilt.** It is essential that all one-pipe radiators tilt slightly toward the radiator valve. Over time, settling of the house and sagging floors may cause improper radiator tilt away from the radiator valve and the steam pipe. This causes condensed water to collect in the bottom of the radiator, which can then block or reduce the flow



Energy Conservation Opportunities for Mechanical Equipment

of steam to the radiator. Two pipe radiators, however, should be tilted away from the radiator valve.

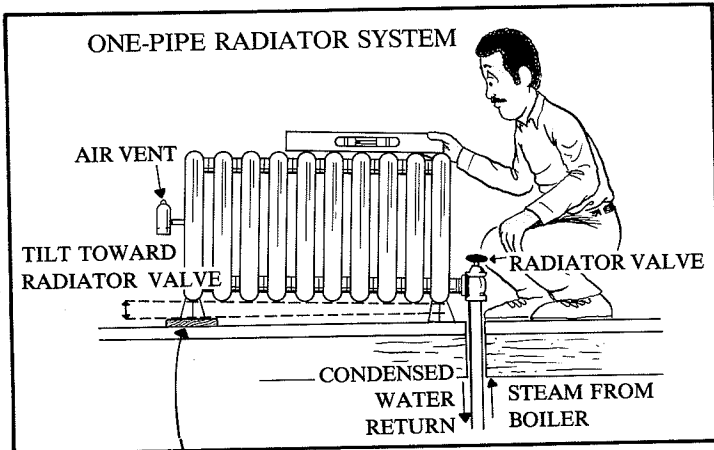

To restore the proper radiator tilt, insert a small wood shim (block or wedge) beneath the side of the radiator furthest away from the radiator valve. This allows the condensed water to flow freely back to the boiler where it is reheated into steam.

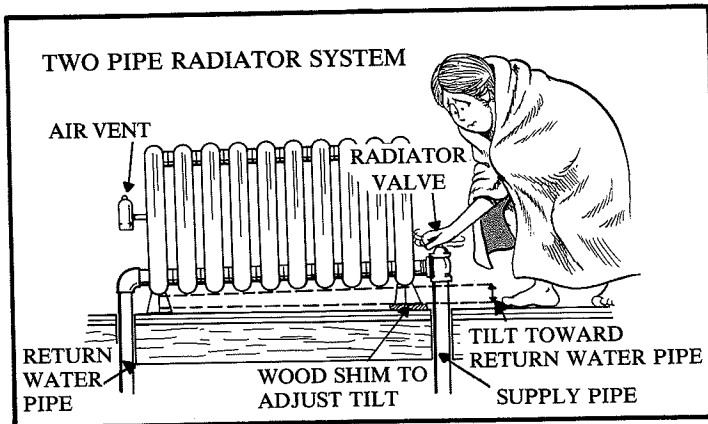

- Adjusting Vent Valves.** If radiators are not heating up equally, even after radiator valves and the tilt have been adjusted, then check the top of each radiator vent valve to ensure it is open and unclogged. The heat will be distributed most effectively if the vent valves on radiators in rooms furthest away from the central boiler are opened more than the vent valves on radiators in rooms located closer to the boiler.

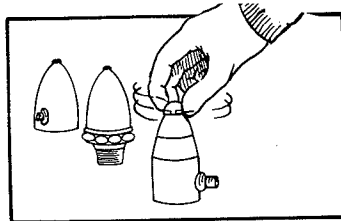

Most vent valves can be adjusted. Open and close by turning the uppermost part of the valve.

- Insulate Heat Pipes.** Heat pipes, especially those in unheated parts of the house, should be insulated wherever these pipes are accessible.
- Add Heat Reflectors Behind Radiators.** A thin bright colored metal sheet behind the radiator reflects heat toward the room and helps reduce heat loss directly through the wall.

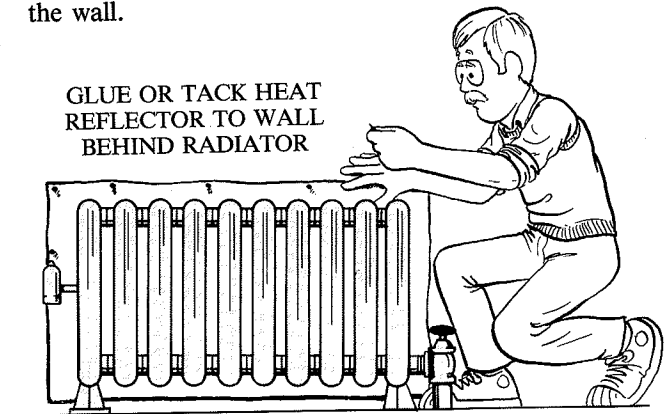

- Turn Off Radiators.** Turning off radiator valves in rooms not frequently used allows more heat to move through radiators left open in occupied parts of the house.
- Thermostatic Radiator Controls.** Vent valves that automatically adjust radiator temperatures are available for approximately \$14 to \$100 per radiator. These energy saving devices are discussed in more detail in the following section on Hot Water Heating Systems.

B. Hot Water Heating Systems

Residential hot water heating systems are of two general types: gravity circulation systems and forced circulation systems. Gravity systems merely rely on the natural upward movement of heated water to circulate to radiators, and therefore, use no pumping devices. Forced circulation systems use pumps to move heated water through the system.

Hot water heating systems are easily distinguished from steam systems because water system radiators have a small "bleeder valve" at one end. Most hot water heating systems are two-pipe systems. That is, radiators have one pipe for water entering and a second pipe at the opposite end for water returning to the central boiler. Some hot water systems use baseboard heaters, that is, pipes with convector fins that radiate heat. Baseboard heaters are less common in old homes but they function on the same principle as old cast iron radiators.



- **Bleeding Radiators.** Excess air in radiators prevents hot water from entering and filling the radiator. This results in cool or only partially heated radiators. "Bleeding", or purging excess air from the system, is relatively simple and can add to the efficiency of your hot water system. The bleeder valve can be opened with a small screwdriver, long-nose pliers, or a special "key" (similar to a miniature skate key), depending upon the type of valve.

BLEEDING CAST IRON RADIATORS AND CONVECTORS

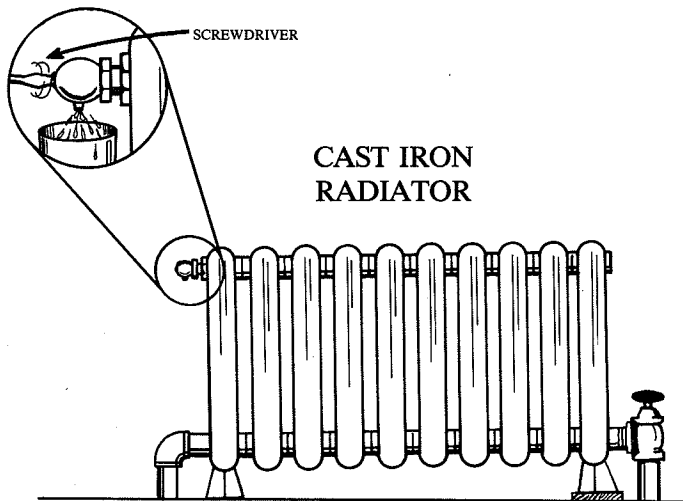

To bleed the radiator, open the valve gently to allow the excess air to escape. Stand by with an empty glass or bowl. When a stream of water squirts out indicating the air has been released, close the valve immediately. Repeat this process with each radiator.

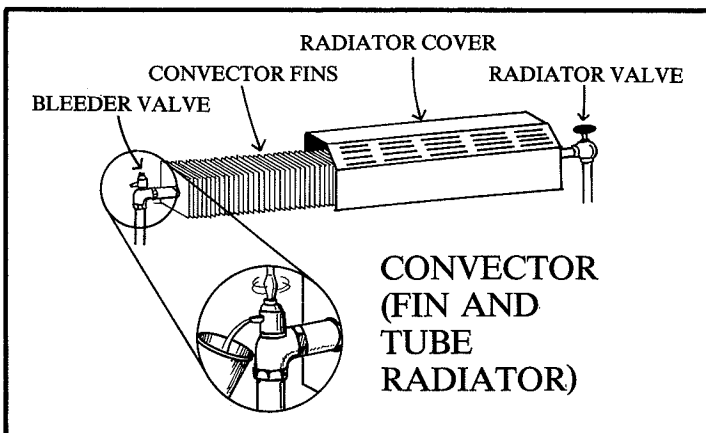

- **Insulate Pipes.** Insulate pipes in unheated areas of the house where the pipes are readily accessible.
- **Thermostatic Radiator Controls.** Thermostatic valves automatically regulate the amount of heat given off by each radiator. Radiators without thermostatic valves are difficult to control. Consequently, you may be overheating some rooms to get enough heat in others. Some thermostatic radiator controls are available with automatic setback (clock) features, which allow you to adjust radiator heat to your needs during different times of the day. Do-it-yourself plumbers can purchase these valves from a plumbing equipment store, or directly from a plumber. Otherwise, call a professional to install thermostatic devices.

C. Boiler and Mechanical Maintenance

With any heating or cooling equipment in your home, it is best to leave adjustments and cleaning to a professional unless you have the original service manual or are generally familiar with your heating equipment. Maintenance is easy, and you can learn what to do by watching a professional. The basic things that keep your system running efficiently are illustrated below.

ENERGY EFFICIENCY TECHNIQUES IN HOT WATER HEATING SYSTEMS

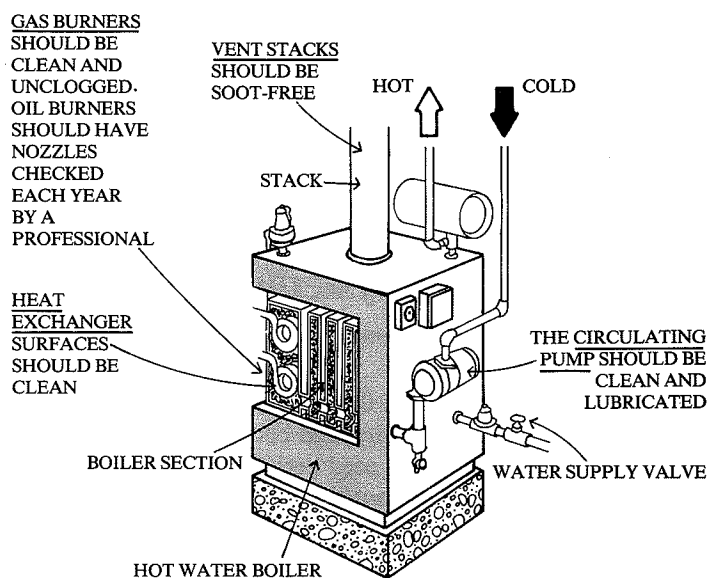



Many older oil burner nozzles are oversized. Ask your fuel oil dealer about installing a smaller nozzle, which will reduce your oil consumption and save you money.

If you have a gas boiler, consult your heating specialist about electric ignition devices that eliminate the need for a constantly burning pilot light.

D. Replacing or Upgrading Your Old Heating System

Your old boiler may have reached the end of its useful life. The decision either to replace your heating system, or upgrade that system should be done with the assistance of a qualified heating specialist.

One major problem with many old central boiler systems (steam or hot water) is that the hot water for heating and the hot water for other domestic uses, such as cleaning and bathing are combined in one system. This is inefficient because you must run the boiler just to heat water when space heating is not needed. It may be cost effective to install a separate water heater so your boiler can be shut down during the warmer periods of the year. A water heater is a relatively high cost item. You should get opinions about savings and estimates for installation from at least two plumbers and/or heating system specialists. If you are replacing a central steam or water heating system, install a separate boiler and a separate hot water heater.

If you wish to upgrade your existing furnace or boiler, consult your fuel supplier or utility company for the best information about new technologies available to improve your older heating system.

be checked for leaks and blockages, and ducts in unheated spaces should be insulated.

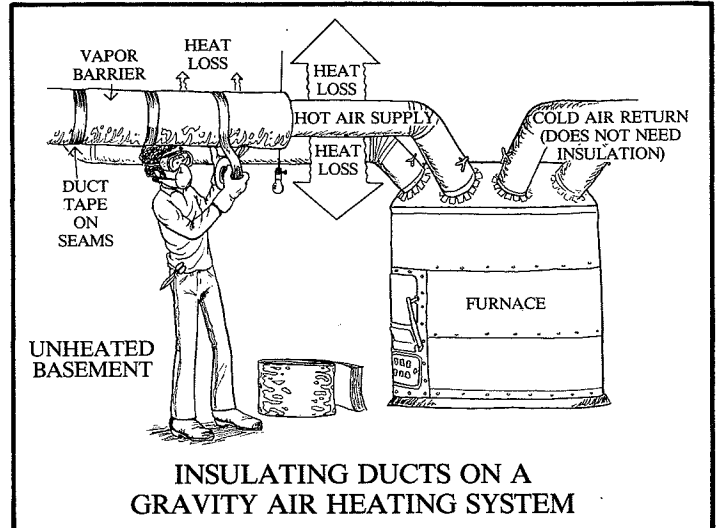

Some old gravity air systems, which rely only on the natural flow of heat upward through the house, can be improved by having a heating equipment specialist install a blower fan. This will improve the flow of air to all portions of the house.

A service manual for your heating and cooling equipment can help with simple cleaning and lubricating tasks that, if done on a regular basis, will maintain your system's efficiency. Chances are, however, that you don't have the manual, so contact the manufacturer or a local heating and cooling specialist for specific information. More difficult adjustments will have to be performed by a qualified heating, ventilation, and air conditioning serviceperson, or a specialist from the utility company.

Simple techniques can be used to make gravity and forced air systems more efficient.

- **Clean Registers and Grilles.** Dirt builds up inside air registers and grilles, forcing your furnace to work harder. These air vents, especially floor grilles common in gravity heating systems, should be vacuumed periodically to help prevent blockage.

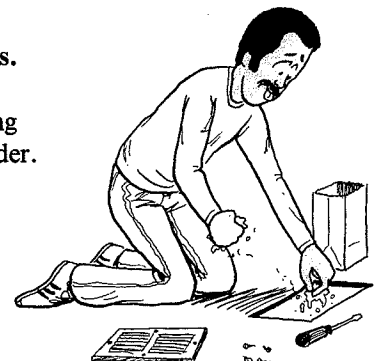

2. Gravity and Forced Air Heating Systems



Many older homes have had their old heating systems replaced with forced air heating and cooling systems. Whether oil, gas, or electric, furnaces need periodic maintenance such as cleaning filters, lubricating motors, and checking the heating mechanisms (burners or electric heating elements). The ducting systems that deliver heated or cooled air to the house should



- **Improving Air Circulation.** Remove all furniture, appliances, and other objects that block grilles and registers and interfere with the flow of air in and out of rooms.

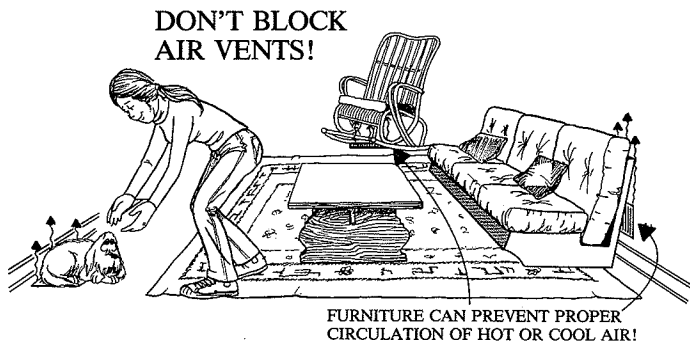

- **Turning Registers.** Registers in many new forced air systems are equipped with moveable blades, while older registers have dampers that help control air flow into a room. Inspect each register to ensure that in the open position the direction of air is forced toward the living area of the room. Because heat rises, heat registers close to the floor can remain positioned with their blades pointing down.

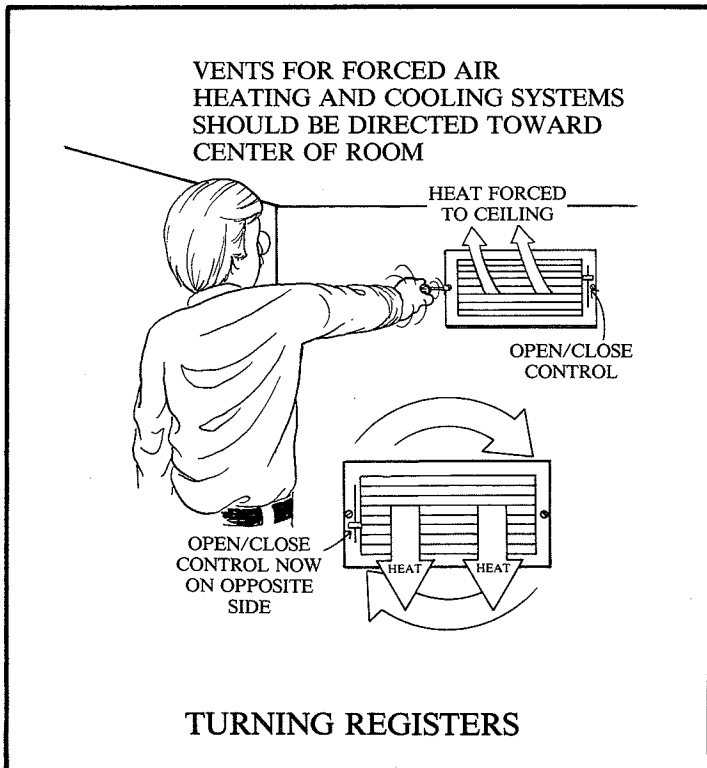

- **Clean or Replace Filters.** The filter on your forced air heating system is located where the air return duct enters the furnace. Some filters are permanent-types, with durable frames and washable materials. Others are disposable and need to be replaced periodically. Clean filters enhance the efficiency of both heating and cooling systems.
- **Clean and Lubricate Blower Fan.** If there is a blower fan on your air system and it is accessible, remove built-up dirt from the blades and motor. Both the fan and the motor need to be lubricated, usually once every heating season.
- **Automatic Clock Setback Thermostat.** Setting your thermostat down at night or when you are away from home is one of the easiest energy conservation measures. If you have difficulty remembering to adjust the thermostat when you go to sleep or when you leave the house, or if you dislike a cool house in the morning, you can save energy by installing an automatic clock setback thermostat.

3. Electric Resistance Heating Systems



If an older home has been renovated or modernized, an electric resistance heating system (baseboard heaters or wall furnaces) may have been installed, particularly if the old house previously relied upon decentralized systems such as fireplace or woodstove heating. Electric resistance heaters require very little maintenance, apart from keeping them dust free.

Here are a few simple tips on keeping electric resistance heating systems running efficiently.

- If your electric heating system uses one central thermostat that controls separate heaters throughout the house, you should consider installing individual thermostats in each room. This will allow you to control room temperatures separately, and to save energy when certain rooms are not in use.
- Dust heating fins periodically, for dust and dirt act as insulators.
- If there is a blower fan in a wall furnace or baseboard heater, lubricate the motor and clean the blades prior to each heating season.



Energy Conservation Opportunities for Mechanical Equipment

- Attach metal heat diverters to baseboard heaters that have blower fans, to direct the flow of warm air into the living area of the room.

METAL HEAT DIVERTER HELPS HEAT FLOW TOWARD ROOM

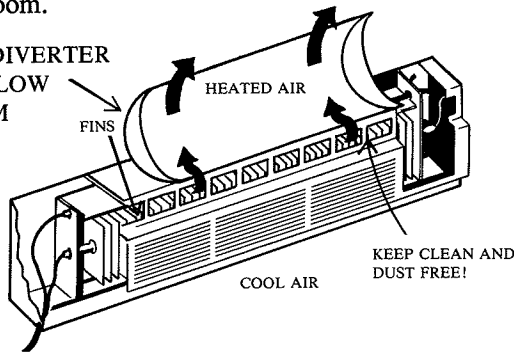

Gas-fired wall furnaces are still found in some parts of the country. These should be cleaned and dusted periodically to prevent clogging.

4. Other Older Home Systems



Many older homes relied on heating fuels and mechanical systems no longer used extensively today. Fireplaces, once a major form of heating in older homes, are often highly valued for their aesthetic appeal although they are a primary source of heat loss in old houses. Wood stoves are used still in many old homes and are enjoying a revival in popularity, as are ceiling fans, which were abandoned with the advent of contemporary air conditioning systems. Each of these systems can be applied effectively in old homes as long as they are properly used and maintained.

Your selection of alternative heating and cooling techniques will depend on the style and condition of your home and on your lifestyle. Energy conscious residents of old homes must be adaptable to the home's heating and cooling "personality," and understand the limitation of the old home's potential to use alternative energy systems. For example, high ceiling Victorian townhouses with large windows are suitable for ceiling fans but small, two-story row houses with low ceilings and limited window space may be more readily adapted to a fan placed in an upstairs window. Your choice of energy saving techniques may involve some experimentation until you discover the right ones for your home.

This section describes some heating and cooling alternatives and suggests ways of applying energy saving ideas to their best advantage.

A. Fireplaces

Some fireplaces in 19th and early to mid-20th century homes were built for wood fires, while others were built for coal fires or gas burning heaters inserted into the hearth. The old fireplaces built for coal and gas fires are only about 12 inches deep, making them unsuitable for wood burning fires that are today so popular for their aesthetic appeal. Unless you plan on using this 12-inch fireplace space for inserting a wood burning fireplace or stove insert, the shallow fireplace should be sealed completely (see section entitled, "Sealing Unused Fireplaces and Chimneys").

Conventional, unimproved fireplaces are about one-third as efficient as a woodburning stove or furnace. Because the fire depends on updrafts to keep burning, it draws warm air from within a house to the outside. Therefore, most of the heat created in a fireplace goes right up the chimney. Up to 20 percent of the air in a house can be drawn up the chimney each hour, and updrafts can still remove air once the fire is out.

The masonry in some old fireplaces and chimneys may have deteriorated over time, and metal linings can be fitted to rehabilitate old fireplaces. All masonry should be repaired to prevent further deterioration and moisture seepage. Then, a metal fireplace or chimney liner should be inserted to protect old brickwork from high flaming wood fires.

There are a few new devices that reduce the energy loss from fireplaces, thus improving efficiency.

- **Convection Devices.** Some convection devices use fans to circulate air. Others, such as fireplace pipes, operate without mechanical equipment. Both types draw room air into a hollow chamber, heating the air before redirecting it back into the room.

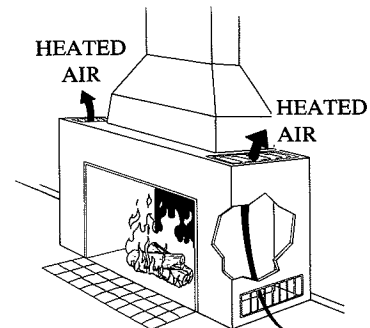

CONVECTION DEVICE FOR INCREASING FIREPLACE EFFICIENCY



FIREPLACE CONVECTION PIPES

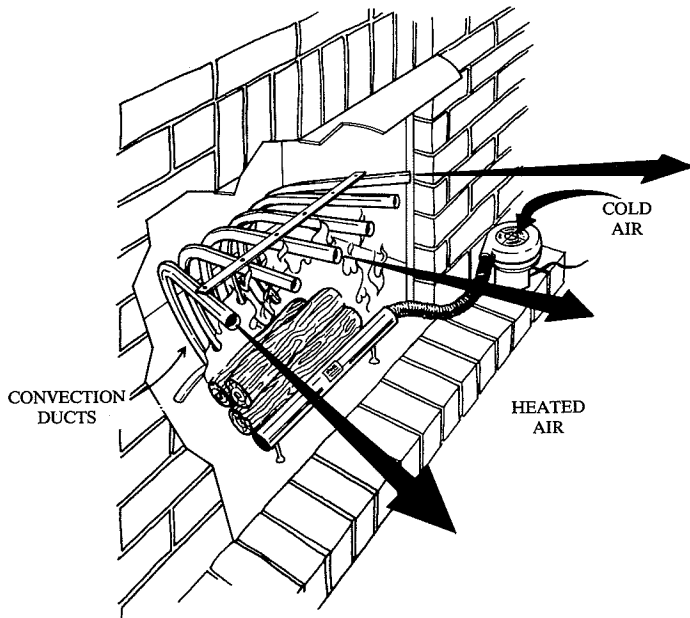

- **Flue Damper.** A properly operating flue damper is essential, because it serves to prevent room heat from escaping through the chimney. During the heating season the damper should remain closed unless the fire is burning. In summertime, the damper can be left open to serve as a “vent” unless, of course, you’re using air conditioning.

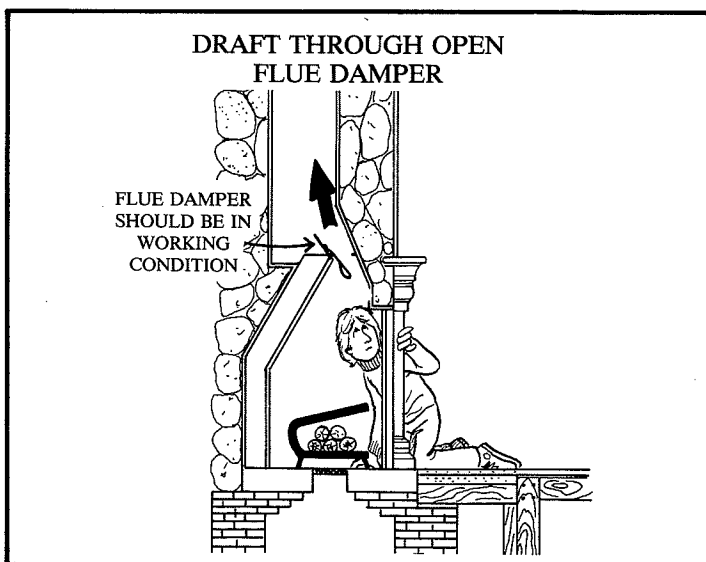

- **Glass Fireplace Screen.** A glass fireplace screen also will serve as a damper when the fireplace is not in use. These screens generally have adjustable vents to regulate the amount of air drawn from the room when the fireplace is being used, thus reducing the wasteful escape of warm air. Reducing the flow of air will also slow the burning of the wood, making your wood supply last longer.
- **Sealing Unused Fireplaces and Chimneys.** If you have a fireplace that isn’t used you should make sure that the flue damper is tightly sealed. The most effective way to reduce fireplace drafts, however, is to seal the front closed, either “permanently” by bricking the hearth closed or by inserting a piece of one-half inch to three-quarter inch plywood, then caulking around the edges.

SEALING UNUSED FIREPLACES WITH PLYWOOD BOARD & CAULKING

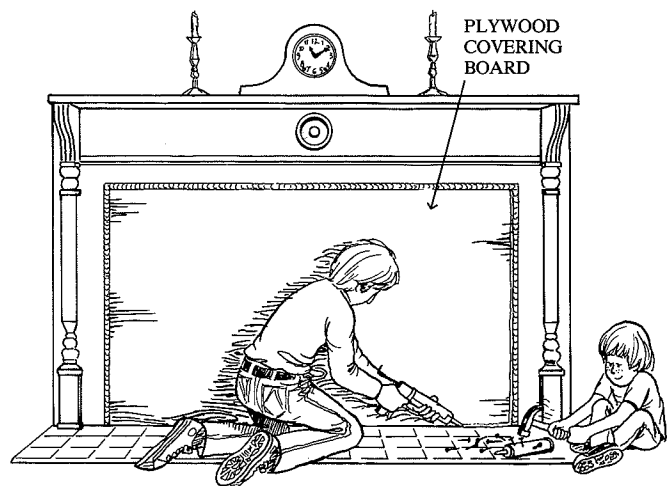

Rigid board insulation can be fastened to the back of the plywood board to help prevent heat loss through the fireplace. If you are worried about the preservation value of an historic home and don’t want to cover the fireplace, make certain that the flue is tightly sealed with a board or metal sheet.

Having sealed the fireplace, the chimney should now be closed at the top to prevent drafts within the chimney, protect against rain and snow, and keep unwanted squirrels and birds from moving in.

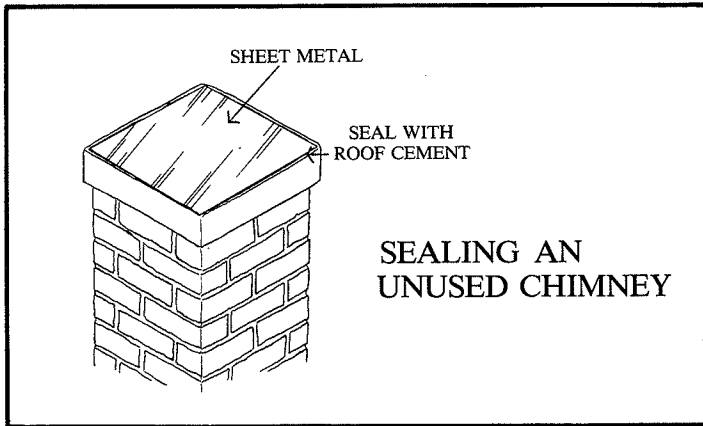

B. Safety Considerations for Wood Stoves

There are a wide variety of wood-burning stoves available, and your choice should depend on price and function as well as safety. Before purchasing a wood stove, check with the following authorities for information that will help protect you and your home.

**ENJOY YOUR
WOOD STOVE
BUT PURCHASE
AND INSTALL
IT WITH SAFETY
IN MIND**

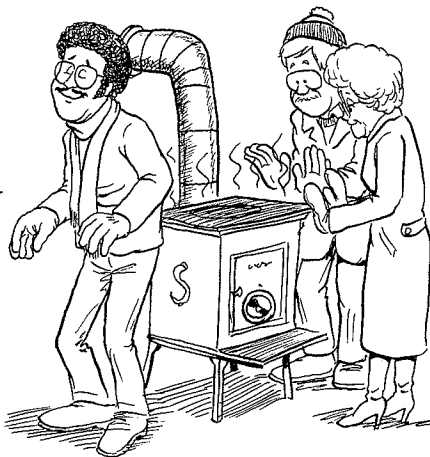

- Local building code or fire marshall's office will tell you about fire codes that apply to wood-burning equipment in your area.
- Your insurance company will tell you if your insurance policy covers the use of wood-burning equipment.
- Information can be obtained from your local consumer protection office regarding known problems with wood stoves in your area.

The correct installation of a wood stove is a complex task that requires special knowledge and care. If you are still uncertain about the correct method of installation after reading the manufacturer's instructions and information received from the local fire marshall, you should hire a specialist to perform the work. Don't risk the safety of people or property.

C. Fans

Fans provide a pleasant, low-cost cooling effect by circulating air throughout the house. The cooling effect can significantly increase comfort even when air temperature is high. In very dry climates, fans often can be used in place of air conditioning.

- **Window Fans.** Window fans are effective when placed in an upper story. By opening the windows on a lower story, cool air is drawn in through the house while warm air is expelled through the upper story.

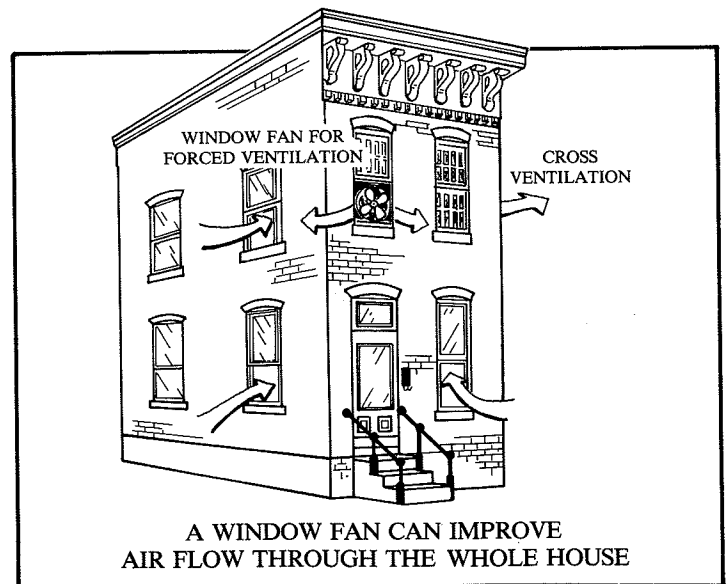

- **Ceiling Fans.** With their large, slow moving blades, ceiling fans are efficient air moving and cooling devices. Originally designed to help cool older homes, ceiling fans are a natural addition. They are available through lighting stores and other retail outlets.

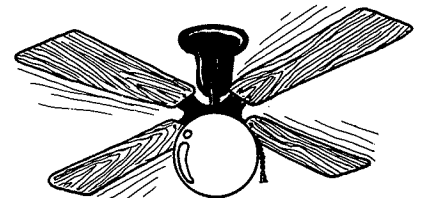



- **Whole-House Fans.** A whole-house fan is usually very effective for ventilating a house but may not be adaptable to a house with a low attic. This type of fan is usually installed in a central location in the ceiling of the uppermost story of the house, drawing air from below and forcing the warm air out through the ventilation openings in the attic.

D. Landscaping Techniques

Trees and shrubs can be located strategically around your home to help block winter winds. Deciduous trees—trees that lose and grow their leaves seasonally—can be used effectively to block unwanted solar gain in the summer but let sunshine in for warmth during the winter.

LANDSCAPE TECHNIQUES: USING TREES AND EARTH TO BEST ADVANTAGE

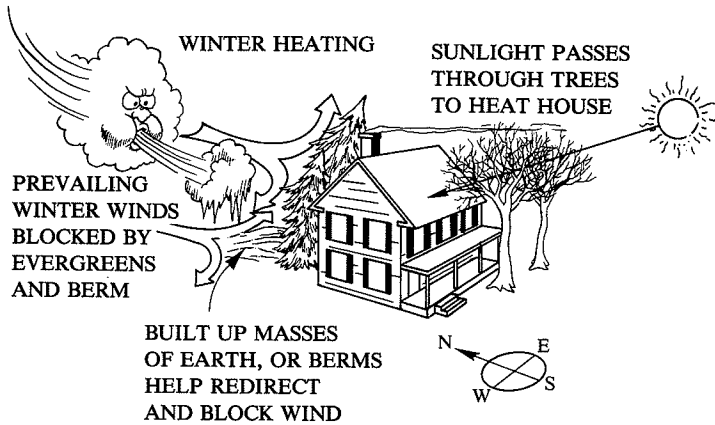

Conifer trees such as evergreens also can provide year-round protection from northern winds. Berms—built-up mounds of earth—can be constructed to help block or divert cold winter winds away from the house. In hot climates, berms are used to direct cooling winds towards the house.

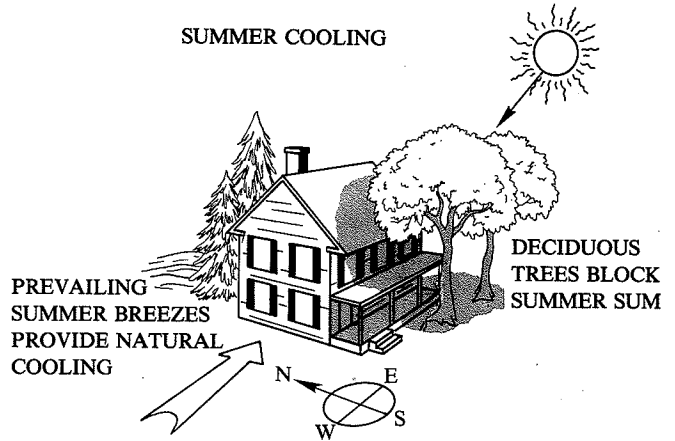

LANDSCAPE TECHNIQUES: USING TREES AND EARTH TO BEST ADVANTAGE

Other Sources of Information on Mechanical Energy Systems

Heating With Wood by the Editors of Family Handyman Magazine. Butterick Publishing, New York, 1978.

Hot Water From The Sun U.S. Department of Housing and Urban Development. May 1980. HUD-PDR-548.

Saving Home Energy: 300 Ways to Cut Costs and Increase Efficiency. Richard V. Nunn. Osmoor House, Birmingham, Alabama, 1975. (Provides photographs of gas forced air maintenance procedures.)

Energy Savers Catalog, by the Editors of Consumer Guide. Publications International, Ltd. Skokie, Illinois, 1977.

Index

- A**
Air Conditioners, 30
Attics, 19
Awnings, 29
- B**
Basement
 Insulating, 25
Bleeder Valve, 37
- C**
Caulking
 Exterior, 24
 Interior, 24
Chimney
 Sealing, 41
Crawl Space
 Insulating, 25
 Venting, 25
- D**
Doors
 Caulking, 31
 Replacement, 33
 Storm, 32
 Threshold, 31
 Weatherstripping, 31
Drafts
 Checking for, 10
Duct Insulation, 38
Ductwork
 Checking for leaks, 38
 Insulating, 38
- E**
Electric Heating, 39
- F**
Fans, 42
Fireplace, 40
Flow Restrictors, 18,
Flue Damper, 41
Furnace
 Filters, 39
 Maintenance, 39
 Pilots, 16
- G**
Glass-Glazing
 Replacing, 26
- H**
Hot Water Heating Systems, 36
- I**
Insulation
 Recommended Levels, 20
 Types, 20
- L**
Landscaping, 43
- P**
Pilot Lights, 16
Pipes
 Heating System, 37
 Insulating, 26, 37
 Water Heating, 17
Putty, 26
- R**
R-Value, 19
Radiators
 Bleeding, 37
 Tilt, 35
 Venting, 37
Roofs, 21
- S**
Shutters, 29
Solar Energy, 43
Steam Heating, 35
Storm Windows, 27
Stoves
 Wood, 42
- T**
Thermostat
 Heating/Cooling, 16
 Location of, 16
 Water Heater, 17
Threshold, 31
Transoms, 15
- V**
Vapor Barrier, 24
Vent Valve, 36
Ventilation
 Attic, 21
 Crawl Space, 25
 House, 42
Vestibules, 15
- W**
Walls
 Brick, 22
 Clapboard, 22
 Frame, 22
 Insulating, 22-24
 Insulation
 Checking for, 8
 Masonry, 22
Water Heater
 Draining Sediment, 17
 Insulating, 17
 Thermostat, 17
Water Heater Insulation, 17
Weatherstripping, 27
Windows
 Caulking, 27
 Glazing, 26
 Putty, 26
 Sash, 26
 Storm, 27
 Weatherstripping, 27
Wood Stoves-See Stoves

Acknowledgements

This manual was prepared by Applied Management Sciences, Inc., of Silver Spring, Maryland, under contract number H-5229 for the Office of Policy Development and Research, U.S. Department of Housing and Urban Development.

The authors wish to thank Mr. Joseph Sherman, Director of the Division of Energy, Building Technology and Standards Research, Mr. Jerome H. Rothenberg, Government Technical Representative, and Dr. Robert J. Kapsch, Government Technical Monitor, for their advice and guidance throughout all phases of writing and production of this manual.

Applied Management Sciences Project Staff

Principal Authors:

Harvey M. Bernstein, Program Executive
Jeffrey M. Seisler, Project Manager
Henry D. Londner

Project Research & Support Staff:

Barbara Zakheim
Sharon L. McIntyre
Elizabeth Zabek
Henry DeLima
Marcia Kircher
Penny K. Piper
Rudy Rael

Mr. Taghi Alereza of ADM Associates, Inc., of Sacramento, California, provided the economic and engineering research support for this document.

UltraGraphics, Inc., of Kensington, Maryland, was responsible for all of the artwork, layout, and production of this manual. In particular, Christopher McDonough, Nancy Herzog, and Jane Flanigan were responsible for the creative artwork, layout, and typesetting respectively, which were developed in conjunction with the principal authors.

Claxton Walker, of Claxton Walker Associates, Potomac, Maryland, provided experienced and insightful technical input to both the written and graphic components of this manual.

Thanks must go also to the following building/construction professionals from the Washington, D.C. metropolitan area who participated in an informational workshop that contributed portions of the technical information contained in this document during the early stages of this project:

Mr. Lou Best
C.I. Mitchell & Best
Mr. Donald Chadbourne
Davenport Insulation, Inc.
Mr. John L. deFief
Mr. Arthur W. Johnson
Arthur W. Johnson Associates
Mr. John Knott
Knott Restoration Service, Inc.

Mr. Harry L. McDonald
Takoma Insulators
Mr. William N. Papian
Claxton Walker Associates
Mr. Walter Shipe
AC & R Insulators
Mr. Michael Thaden
Ward Development Company, Inc.
Mr. M. B. Williams
Claxton Walker Associates

Last, thanks to the members of the Upper King Street Association, of Alexandria, Virginia, who as owners and occupants of older homes participated in the audience sensitivity testing of this document.

Disclaimer

The research and studies forming the basis for this manual were conducted pursuant to a contract with the U.S. Department of Housing and Urban Development (HUD). The statements and conclusions contained herein are those of the contractor and do not necessarily reflect the views of the U.S. Government in general or HUD in particular. This manual is not an official standard, and neither the United States nor HUD nor the contractor makes any warranty, expressed or implied, or assumes responsibility for the accuracy or completeness of the information herein. However, HUD emphasizes that this manual may be reproduced freely by any interested party, so long as no material contained in the manual is changed or deleted in such reproduction, and so long as proper credit is given to HUD in such reproduction.

ANALYTECH